



HVAC Products

SUBMITTAL

Mar 2018

1512 SERIES PUMP CONNECTOR W/150# PLATE FLANGES & TIE RODS

PROJECT:	
CUSTOMER:	
ENGINEER:	
ARCHITECT:	

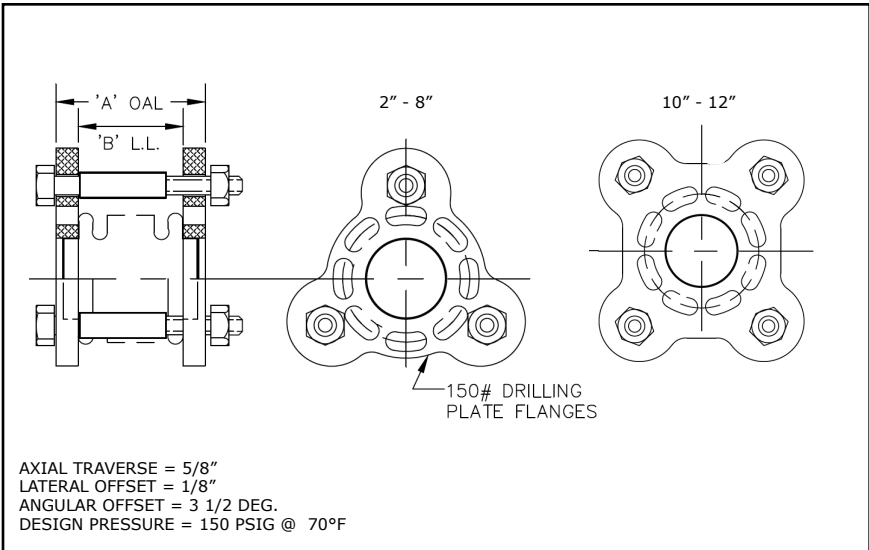

MATERIALS OF CONSTRUCTION	
BELLOWS:	T-304 STN STL
FLANGES:	CARBON STEEL
BOLT/NUT & SLEEVE:	CARBON STEEL

QTY	ID # OR TAG #	DIA (IN)	KEFLEX PART #	'B' LL	'A' OAL	3D Model (.stp)
		2"	F0201512TR1215	4 1/2"	6"	
		2 1/2"	F0241512TR1215	4 1/2"	6"	
		3"	F0301512TR1215	4 1/2"	6"	
		4"	F0401512TR1215	4 1/2"	6"	
		5"	F0501512TR1215	4 1/2"	6"	
		6"	F0601512TR1215	4 1/2"	6"	
		8"	F0801512TR1215	4 1/2"	6"	
		10"	F1001512TR1215	4 1/2"	6"	
		12"	F1201512TR1215	4 1/2"	6"	

IMPORTANT LINKS	
BROCHURE:	
INSTALLATION INSTRUCTIONS:	
TECHNICAL DATA:	
WEBSITE:	KELCOIND.COM

MADE IN THE USA

**1425 LAKE AVE
 WOODSTOCK, IL 60098
 815-334-3600**