



HVAC Products

SUBMITTAL

Mar 2018

308 SERIES DUAL EXPANSION JOINT 2" TRAVEL W/300# PLATE FLANGES

PROJECT:	
CUSTOMER:	
ENGINEER:	
ARCHITECT:	

MATERIALS OF CONSTRUCTION	
'A' PIPE SCH 40:	CARBON STEEL
'B' CAPSULE:	T-304 STN STL
'C' BASE PLATE:	CARBON STEEL
'D' PLATE FLANGES:	CARBON STEEL

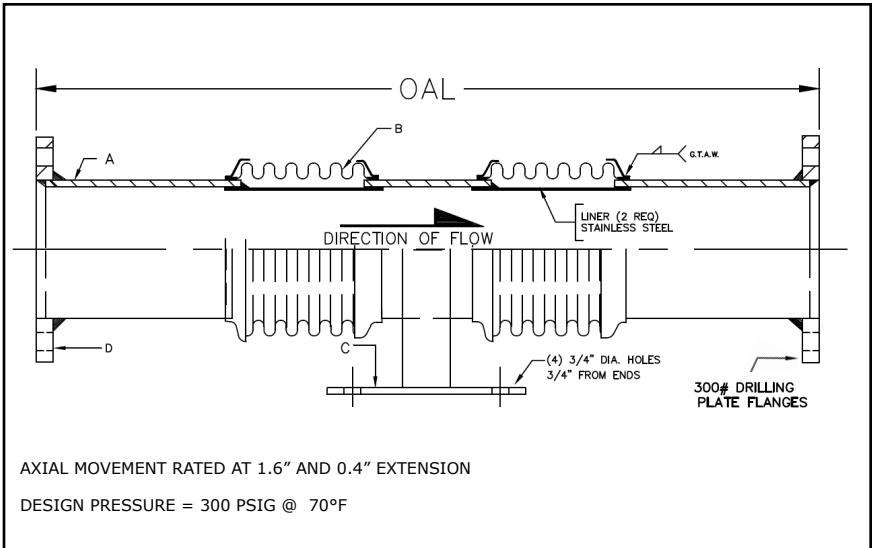

QTY	ID # OR TAG #	DIA (IN)	KEFLEX PART #	OAL	AXIAL FORCE TO COMPRESS (LBS)	WEIGHT (LBS)	3D Model (.stp)
		2"	F020H308DB3002	19"	100	27	
		2 1/2"	F024H308DB3002	19"	200	29	
		3"	F030H308DB3002	19"	150	51	
		4"	F040H308DB3002	19"	400	76	
		5"	F050H308DB3002	19"	225	93	
		6"	F060H308DB3002	19"	250	109	
		8"	F080H308DB3002	19"	400	149	
		10"	F100H308DB3002	19"	600	190	
		12"	F120H308DB3002	19"	350	259	

Typical Installation

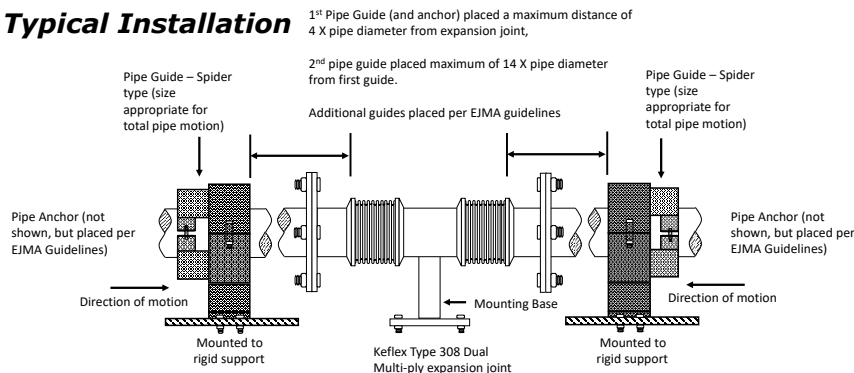

IMPORTANT LINKS

BROCHURE:	
INSTALLATION INSTRUCTIONS:	
TECHNICAL DATA:	
WEBSITE:	KELCOIND.COM



MADE IN THE USA

**1425 LAKE AVE
WOODSTOCK, IL 60098
815-334-3600**