



HVAC Products

# SUBMITTAL

Mar 2018

## 308 SERIES DUAL EXPANSION JOINT 6" TRAVEL W/300# PLATE FLANGES

<b>PROJECT:</b>	
<b>CUSTOMER:</b>	
<b>ENGINEER:</b>	
<b>ARCHITECT:</b>	

MATERIALS OF CONSTRUCTION	
'A' PIPE SCH 40:	CARBON STEEL
'B' CAPSULE:	T-304 STN STL
'C' BASE PLATE:	CARBON STEEL
'D' PLATE FLANGES:	CARBON STEEL

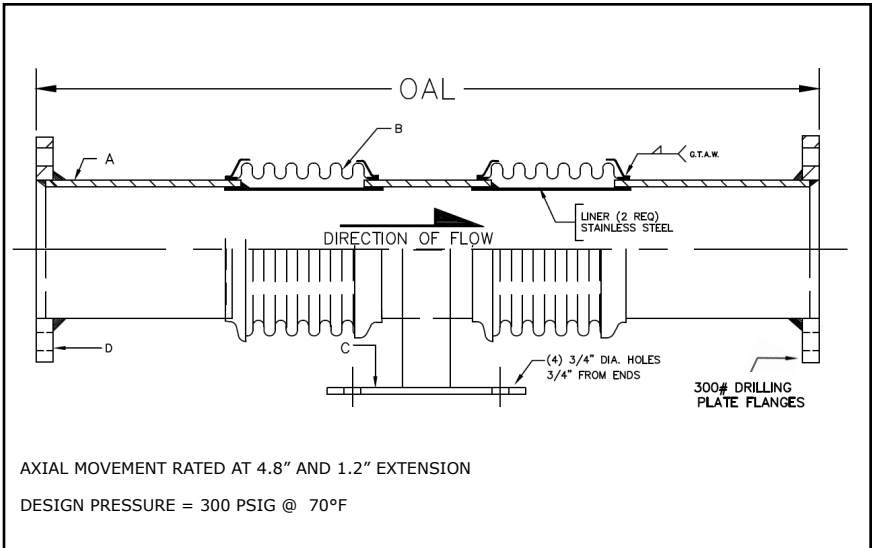

QTY	ID # OR TAG #	DIA (IN)	KEFLEX PART #	OAL	AXIAL FORCE TO COMPRESS (LBS)	WEIGHT (LBS)	3D Model (.stp)
		8"	F080H308DB3006	30"	750	158	
		10"	F100H308DB3006	30"	1000	201	
		12"	F120H308DB3006	30"	600	270	

### Typical Installation

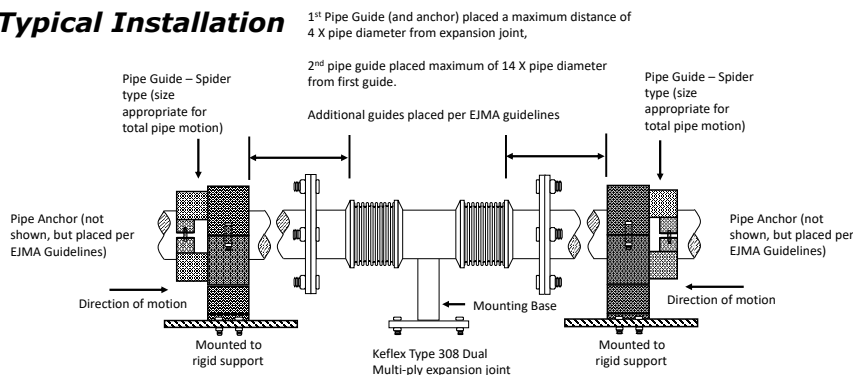

### IMPORTANT LINKS

BROCHURE:	
INSTALLATION INSTRUCTIONS:	
TECHNICAL DATA:	
WEBSITE:	<a href="http://KELCOIND.COM">KELCOIND.COM</a>



MADE IN THE USA

1425 LAKE AVE  
WOODSTOCK, IL 60098  
815-334-3600