

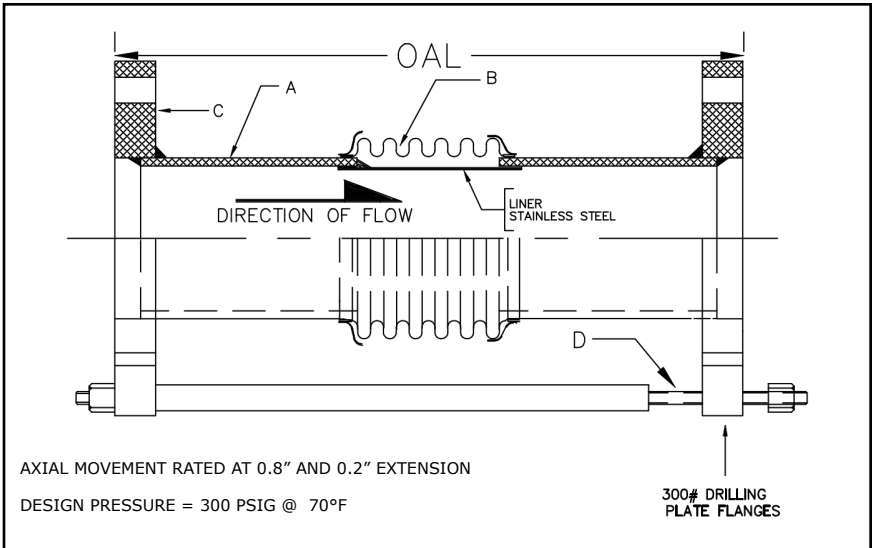









308 SERIES EXPANSION JOINT 1" TRAVEL W/300# PLATE FLANGES & TIE RODS

PROJECT:	
CUSTOMER:	
ENGINEER:	
ARCHITECT:	



MATERIALS OF CONSTRUCTION	
'A' PIPE SCH 40:	CARBON STEEL
'B' CAPSULE:	T-304 STN STL
'C' PLATE FLANGE:	CARBON STEEL
'D' TIE RODS/SPACERS	CARBON STEEL

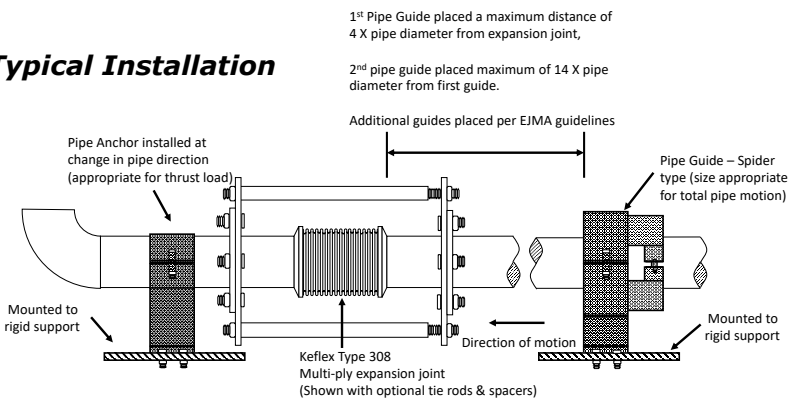

QTY	ID # OR TAG #	DIA (IN)	KEFLEX PART #	OAL	AXIAL FORCE TO COMPRESS (LBS)	WEIGHT (LBS)	3D Model (.stp)
		2"	F020H308T3001	13"	100	26	
		2 1/2"	F024H308T3001	13"	200	31	
		3"	F030H308T3001	13"	150	35	
		4"	F040H308T3001	13"	400	43	
		5"	F050H308T3001	13"	225	57	
		6"	F060H308T3001	13"	250	70	
		8"	F080H308T3001	13"	400	106	
		10"	F100H308T3001	13"	600	138	
		12"	F120H308T3001	13"	350	192	

Typical Installation



IMPORTANT LINKS	
BROCHURE:	
INSTALLATION INSTRUCTIONS:	
TECHNICAL DATA:	
WEBSITE:	KELCOIND.COM

 **MADE IN THE USA**

**1425 LAKE AVE
WOODSTOCK, IL 60098
815-334-3600**