



HVAC Products

SUBMITTAL

Mar 2018

308 SERIES EXPANSION JOINT 3" TRAVEL W/300# PLATE FLANGES & TIE RODS

PROJECT:	
CUSTOMER:	
ENGINEER:	
ARCHITECT:	

MATERIALS OF CONSTRUCTION	
'A' PIPE SCH 40:	CARBON STEEL
'B' CAPSULE:	T-304 STN STL
'C' PLATE FLANGE:	CARBON STEEL
'D' TIE RODS/SPACERS	CARBON STEEL

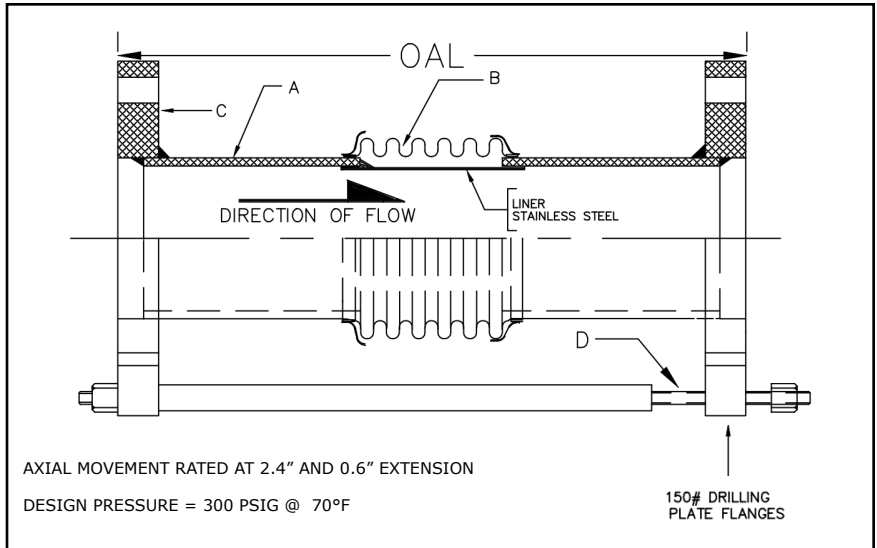

QTY	ID # OR TAG #	DIA (IN)	KEFLEX PART #	OAL	AXIAL FORCE TO COMPRESS (LBS)	WEIGHT (LBS)	3D Model (.stp)
		8"	F080H308T3003	17"	750	120	
		10"	F100H308T3003	17"	1000	158	
		12"	F120H308T3003	17"	600	211	

Typical Installation

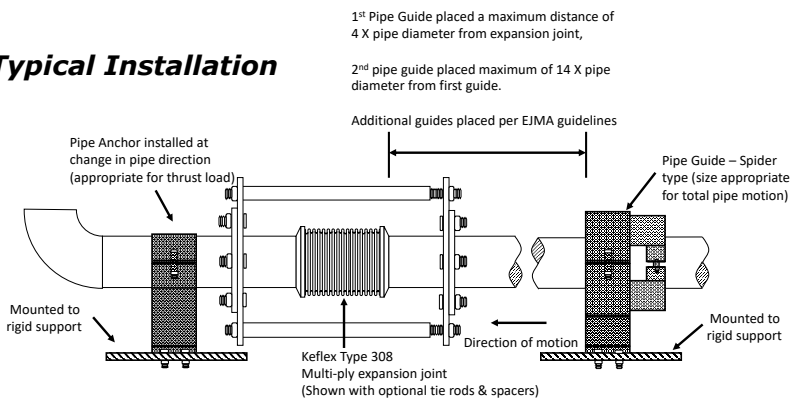

IMPORTANT LINKS	
BROCHURE:	
INSTALLATION INSTRUCTIONS:	
TECHNICAL DATA:	
WEBSITE:	KELCOIND.COM



MADE IN THE USA

**1425 LAKE AVE
WOODSTOCK, IL 60098
815-334-3600**