

308 SERIES DUAL EXPANSION JOINT 2" TRAVEL W/WELD ENDS - HIGH PRESSURE

PROJECT:	
CUSTOMER:	
ENGINEER:	
ARCHITECT:	

MATERIALS OF CONSTRUCTION	
'A' PIPE SCH 40:	CARBON STEEL
'B' CAPSULE:	T-304 STN STL
'C' BASE PLATE:	CARBON STEEL
'D' PLATE FLANGES:	CARBON STEEL

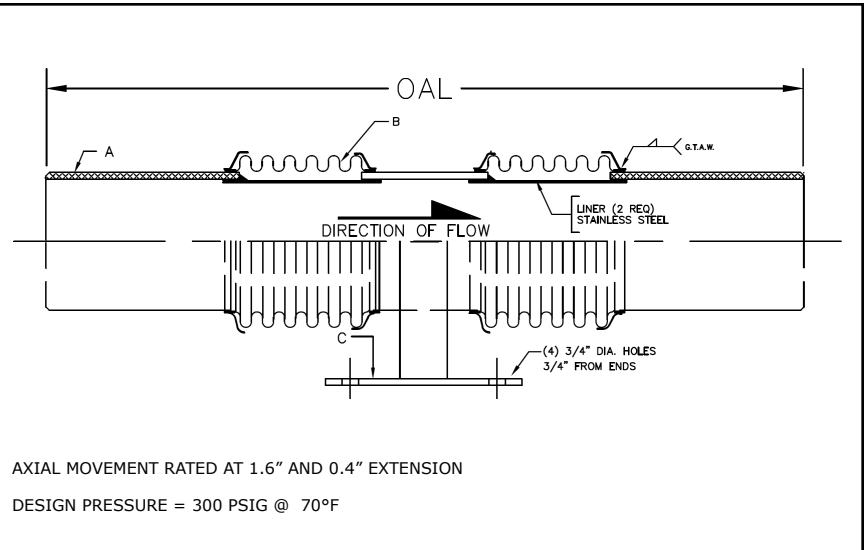

QTY	ID # OR TAG #	DIA (IN)	KEFLEX PART #	OAL	AXIAL FORCE TO COMPRESS (LBS)	WEIGHT (LBS)	3D Model (.stp)
		2"	F020H308DB902	19"	100	16	
		2 1/2"	F024H308DB902	19"	200	16	
		3"	F030H308DB902	19"	150	32	
		4"	F040H308DB902	19"	400	47	
		5"	F050H308DB902	19"	225	56	
		6"	F060H308DB902	19"	250	67	
		8"	F080H308DB902	19"	400	88	
		10"	F100H308DB902	19"	600	115	
		12"	F120H308DB902	19"	350	149	

Typical Installation

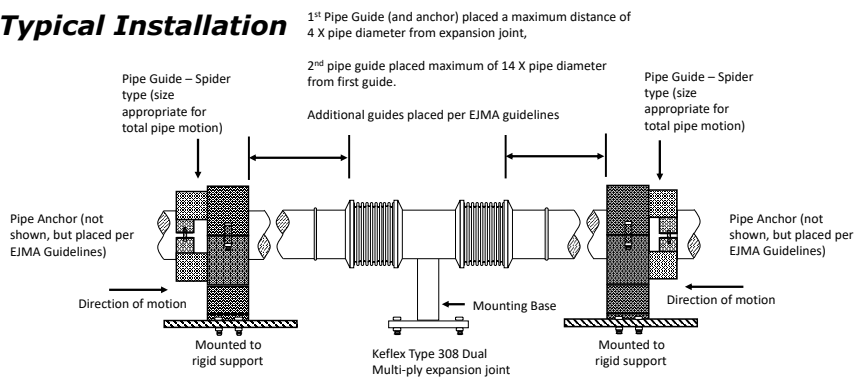

IMPORTANT LINKS	
BROCHURE:	
INSTALLATION INSTRUCTIONS:	
TECHNICAL DATA:	
WEBSITE:	KELCOIND.COM

MADE IN THE USA

**1425 LAKE AVE
WOODSTOCK, IL 60098
815-334-3600**