



HVAC Products

SUBMITTAL

Mar 2018

308 SERIES EXPANSION JOINT 1" TRAVEL W/WELD ENDS & TIE RODS - HIGH PRESSURE

PROJECT:	
CUSTOMER:	
ENGINEER:	
ARCHITECT:	

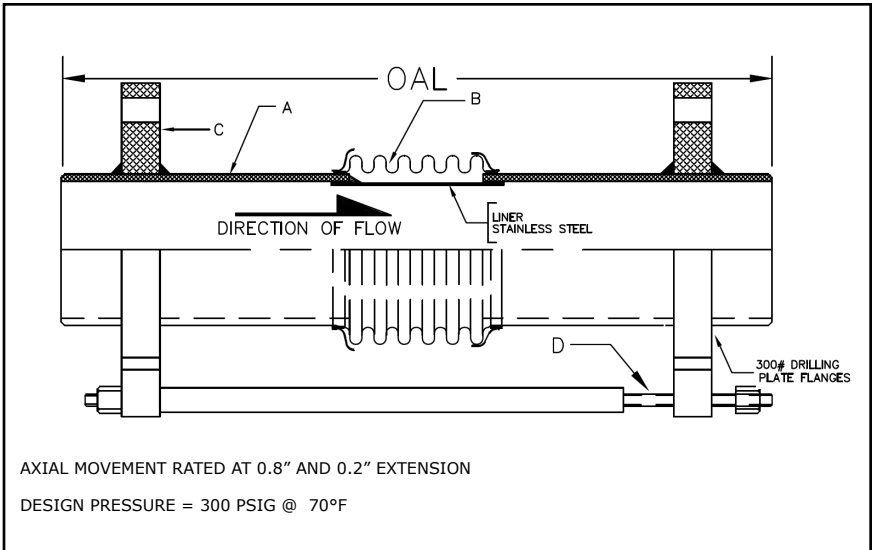

MATERIALS OF CONSTRUCTION	
'A' PIPE SCH 40:	CARBON STEEL
'B' CAPSULE:	T-304 STN STL
'C' PLATE FLANGE:	CARBON STEEL
'D' TIE RODS/SPACERS	CARBON STEEL

QTY	ID # OR TAG #	DIA (IN)	KEFLEX PART #	OAL	AXIAL FORCE TO COMPRESS (LBS)	WEIGHT (LBS)	3D Model (.stp)
		2"	F020H308T901	13"	100	26	
		2 1/2"	F024H308T901	13"	200	31	
		3"	F030H308T901	13"	150	35	
		4"	F040H308T901	13"	400	43	
		5"	F050H308T901	13"	225	57	
		6"	F060H308T901	13"	250	70	
		8"	F080H308T901	13"	400	106	
		10"	F100H308T901	13"	600	138	
		12"	F120H308T901	13"	350	192	

Typical Installation

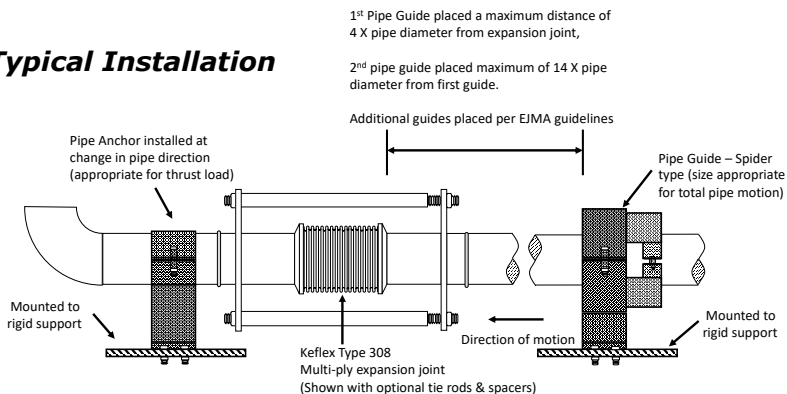

IMPORTANT LINKS	
BROCHURE:	
INSTALLATION INSTRUCTIONS:	
TECHNICAL DATA:	
WEBSITE:	KELCOIND.COM

MADE IN THE USA

**1425 LAKE AVE
WOODSTOCK, IL 60098
815-334-3600**