

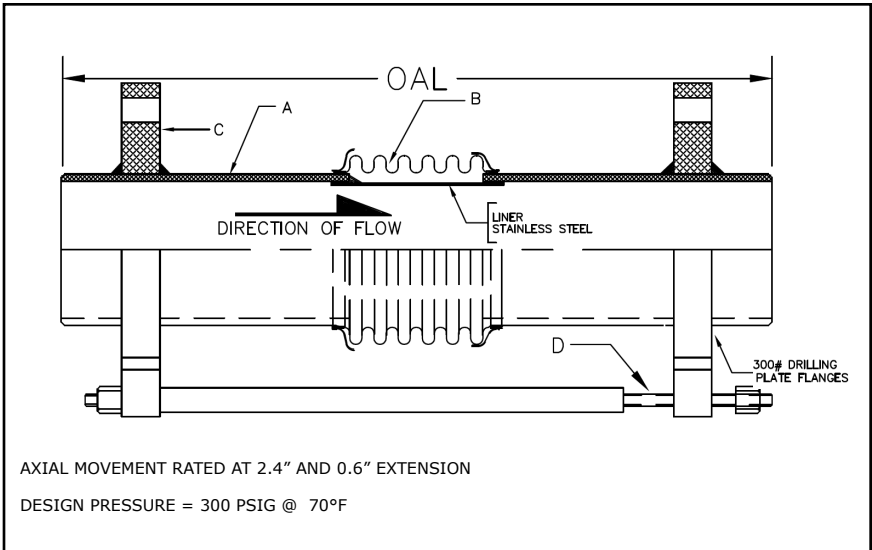



308 SERIES EXPANSION JOINT 3" TRAVEL W/ WELD ENDS & TIE RODS - HIGH PRESSURE

PROJECT:	
CUSTOMER:	
ENGINEER:	
ARCHITECT:	





MATERIALS OF CONSTRUCTION	
'A' PIPE SCH 40:	CARBON STEEL
'B' CAPSULE:	T-304 STN STL
'C' PLATE FLANGE:	CARBON STEEL
'D' TIE RODS/SPACERS	CARBON STEEL

QTY	ID # OR TAG #	DIA (IN)	KEFLEX PART #	OAL	AXIAL FORCE TO COMPRESS (LBS)	WEIGHT (LBS)	3D Model (.stp)
		8"	F080H308T903	17"	750	120	
		10"	F100H308T903	17"	1000	158	
		12"	F120H308T903	17"	600	211	

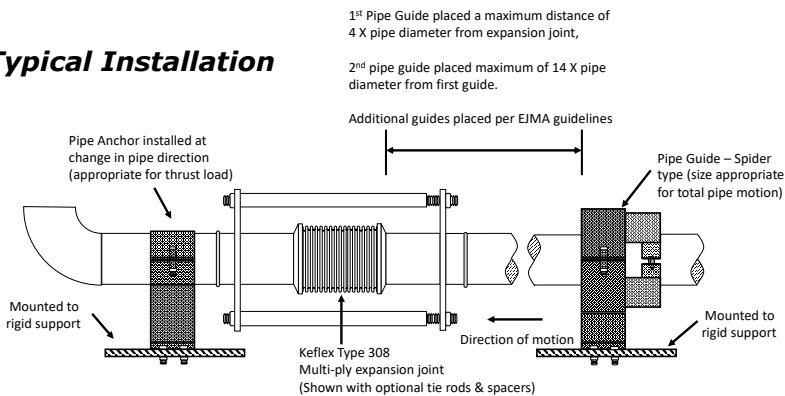
Typical Installation



IMPORTANT LINKS	
BROCHURE:	
INSTALLATION INSTRUCTIONS:	
TECHNICAL DATA:	
WEBSITE:	KELCOIND.COM

 **MADE IN THE USA**

**1425 LAKE AVE
WOODSTOCK, IL 60098
815-334-3600**