



HVAC Products

SUBMITTAL

Mar 2018

308 SERIES DUAL EXPANSION JOINT 4" TRAVEL W/150# PLATE FLANGES

PROJECT:	
CUSTOMER:	
ENGINEER:	
ARCHITECT:	

MATERIALS OF CONSTRUCTION	
'A' PIPE SCH 40:	CARBON STEEL
'B' CAPSULE:	T-304 STN STL
'C' BASE PLATE:	CARBON STEEL
'D' PLATE FLANGES:	CARBON STEEL

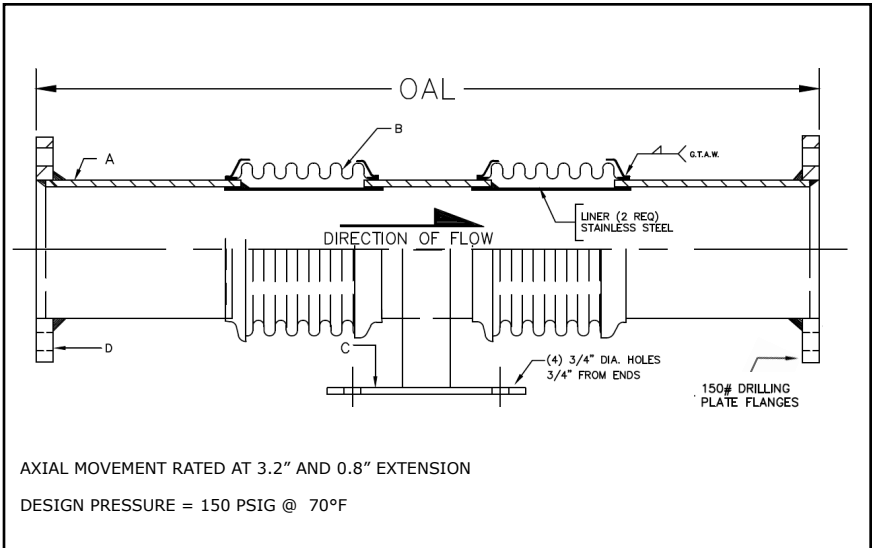

QTY	ID # OR TAG #	DIA (IN)	KEFLEX PART #	OAL	AXIAL FORCE TO COMPRESS (LBS)	WEIGHT (LBS)	3D Model (.stp)
		2"	F020M308DB1504	24"	175	27	
		2 1/2"	F024M308DB1504	24"	350	27	
		3"	F030M308DB1504	24"	225	49	
		4"	F040M308DB1504	24"	575	66	
		5"	F050M308DB1504	24"	350	81	
		6"	F060M308DB1504	24"	400	95	
		8"	F080M308DB1504	24"	575	133	
		10"	F100M308DB1504	24"	850	170	
		12"	F120M308DB1504	24"	475	234	

Typical Installation

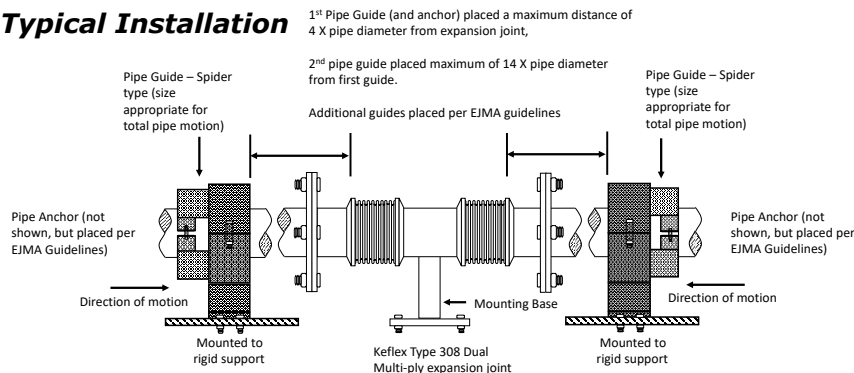

IMPORTANT LINKS

BROCHURE:	
INSTALLATION INSTRUCTIONS:	
TECHNICAL DATA:	
WEBSITE:	KELCOIND.COM



MADE IN THE USA

**1425 LAKE AVE
WOODSTOCK, IL 60098
815-334-3600**