



HVAC Products

SUBMITTAL

Mar 2018

308 SERIES EXPANSION JOINT 4" TRAVEL W/150# PLATE FLANGES & TIE RODS

PROJECT:	
CUSTOMER:	
ENGINEER:	
ARCHITECT:	

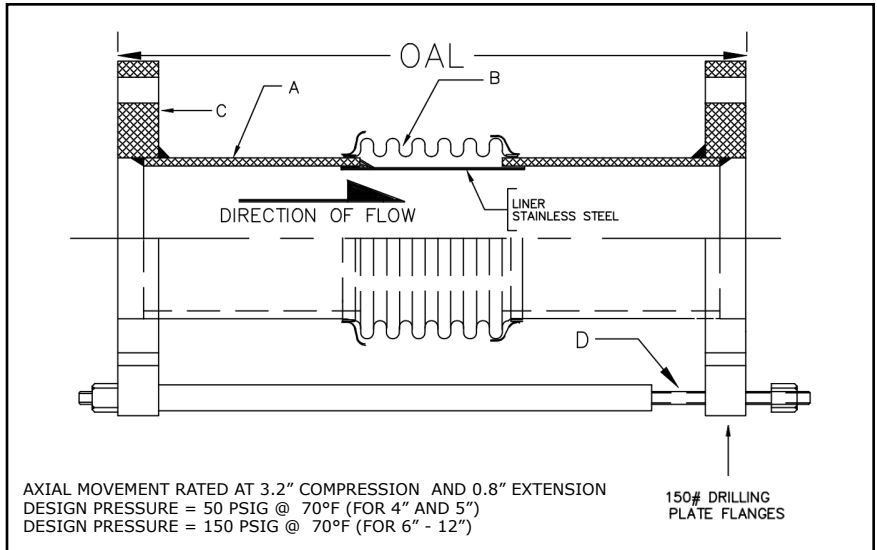

MATERIALS OF CONSTRUCTION	
'A' PIPE SCH 40:	CARBON STEEL
'B' CAPSULE:	T-304 STN STL
'C' PLATE FLANGE:	CARBON STEEL
'D' TIE RODS/SPACERS	CARBON STEEL

QTY	ID # OR TAG #	DIA (IN)	KEFLEX PART #	OAL	AXIAL FORCE TO COMPRESS (LBS)	WEIGHT (LBS)	3D Model (.stp)
		4"	F040L308T1504	21"	625	56	
		5"	F050L308T1504	21"	425	74	
		6"	F060M308T1504	21"	500	90	
		8"	F080M308T1504	21"	650	131	
		10"	F100M308T1504	21"	900	173	
		12"	F120M308T1504	21"	550	234	

Typical Installation

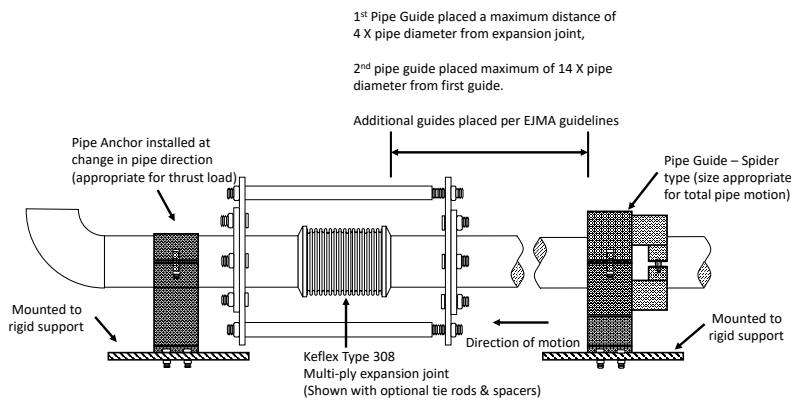

IMPORTANT LINKS	
BROCHURE:	
INSTALLATION INSTRUCTIONS:	
TECHNICAL DATA:	
WEBSITE:	KELCOIND.COM



MADE IN THE USA

1425 LAKE AVE
 WOODSTOCK, IL 60098
 815-334-3600