



HVAC Products

SUBMITTAL

Mar 2018

308 SERIES DUAL EXPANSION JOINT 4" TRAVEL W/WELD ENDS

PROJECT:	
CUSTOMER:	
ENGINEER:	
ARCHITECT:	

MATERIALS OF CONSTRUCTION	
'A' PIPE SCH 40:	CARBON STEEL
'B' CAPSULE:	T-304 STN STL
'C' BASE PLATE:	CARBON STEEL
'D' PLATE FLANGES:	CARBON STEEL

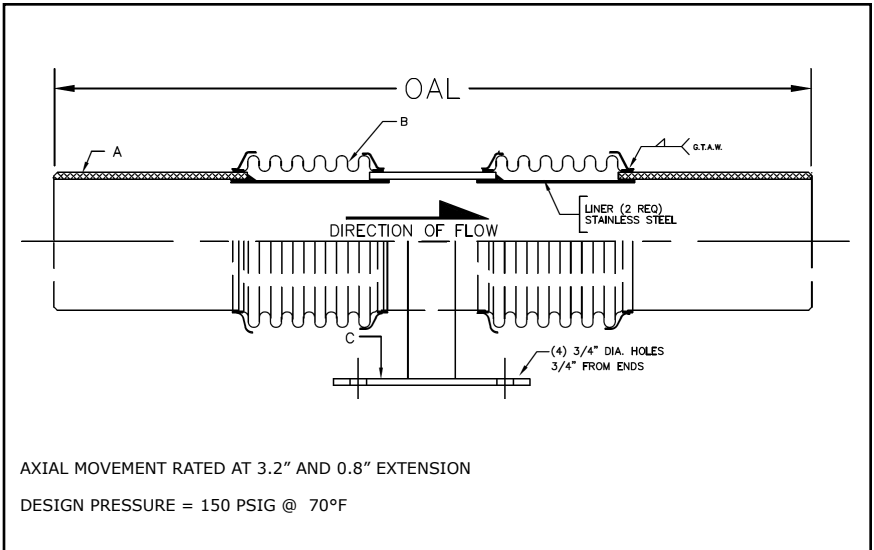

QTY	ID # OR TAG #	DIA (IN)	KEFLEX PART #	OAL	AXIAL FORCE TO COMPRESS (LBS)	WEIGHT (LBS)	3D Model (.stp)
		2"	F020M308DB904	24"	175	19	
		2 1/2"	F024M308DB904	24"	350	19	
		3"	F030M308DB904	24"	225	37	
		4"	F040M308DB904	24"	575	52	
		5"	F050M308DB904	24"	350	61	
		6"	F060M308DB904	24"	400	72	
		8"	F080M308DB904	24"	575	91	
		10"	F100M308DB904	24"	850	120	
		12"	F120M308DB904	24"	475	154	

Typical Installation

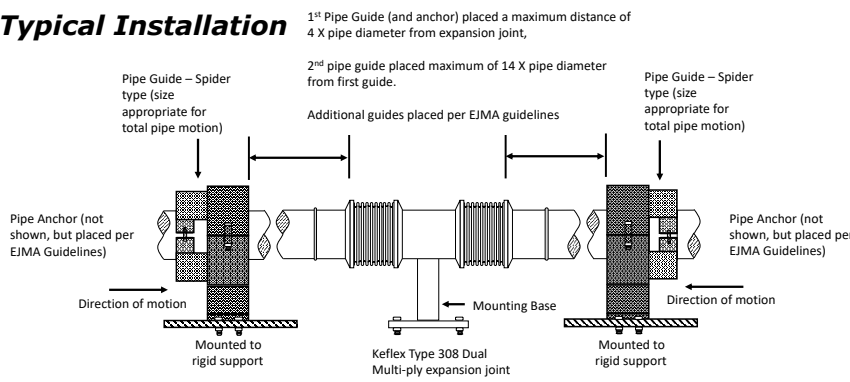

IMPORTANT LINKS	
BROCHURE:	
INSTALLATION INSTRUCTIONS:	
TECHNICAL DATA:	
WEBSITE:	KELCOIND.COM

MADE IN THE USA

**1425 LAKE AVE
WOODSTOCK, IL 60098
815-334-3600**