

308 SERIES DUAL EXPANSION JOINT 8" TRAVEL W/WELD ENDS

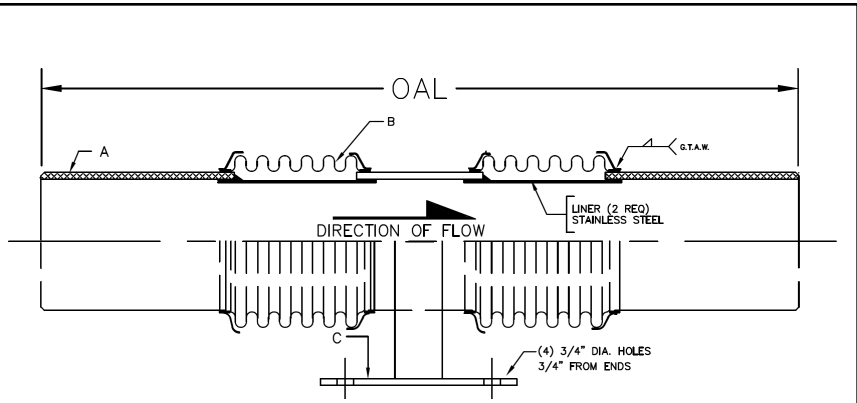





PROJECT:	
CUSTOMER:	
ENGINEER:	
ARCHITECT:	

MATERIALS OF CONSTRUCTION	
'A' PIPE SCH 40:	CARBON STEEL
'B' CAPSULE:	T-304 STN STL
'C' BASE PLATE:	CARBON STEEL
'D' PLATE FLANGES:	CARBON STEEL







AXIAL MOVEMENT RATED AT 6.4" AND 1.6" EXTENSION

DESIGN PRESSURE = 50 PSIG @ 70°F FOR 4" AND 5"
DESIGN PRESSURE = 150 PSIG @ 70°F FOR 6" - 12"

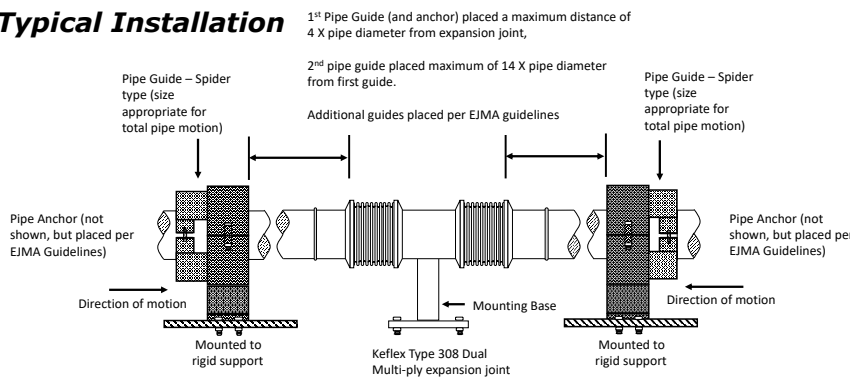
QTY	ID # OR TAG #	DIA (IN)	KEFLEX PART #	OAL	AXIAL FORCE TO COMPRESS (LBS)	WEIGHT (LBS)	3D Model (.stp)
		4"	F040L308DB908	40"	625	67	
		5"	F050L308DB908	40"	425	71	
		6"	F060M308DB908	40"	500	84	
		8"	F080M308DB908	40"	650	101	
		10"	F100M308DB908	40"	900	130	
		12"	F120M308DB908	40"	550	165	

Typical Installation



IMPORTANT LINKS	
BROCHURE:	
INSTALLATION INSTRUCTIONS:	
TECHNICAL DATA:	
WEBSITE:	KELCOIND.COM

 **MADE IN THE USA**

**1425 LAKE AVE
WOODSTOCK, IL 60098
815-334-3600**