



HVAC Products

SUBMITTAL

Mar 2018

308 SERIES DUAL EXPANSION JOINT 8" TRAVEL W/WELD ENDS & TIE RODS

PROJECT:	
CUSTOMER:	
ENGINEER:	
ARCHITECT:	

MATERIALS OF CONSTRUCTION	
'A' PIPE SCH 40:	CARBON STEEL
'B' CAPSULE:	T-304 STN STL
'C' TIE RODS/SPACERS:	CARBON STEEL
'D' PLATE FLANGES:	CARBON STEEL

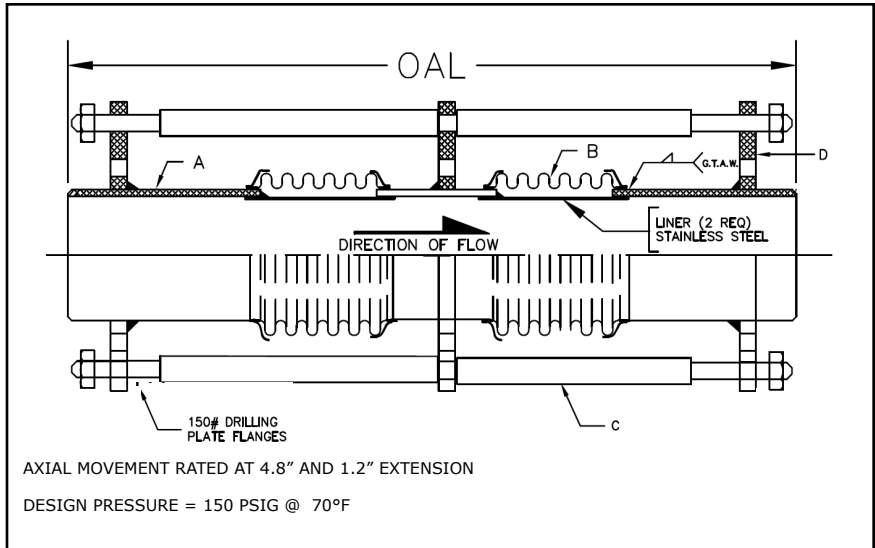

QTY	ID # OR TAG #	DIA (IN)	KEFLEX PART #	OAL	AXIAL FORCE TO COMPRESS (LBS)	WEIGHT (LBS)	3D Model (.stp)
		4"	F040L308DT908	40"	625	105	
		5"	F050L308DT908	40"	425	121	
		6"	F060M308DT908	40"	500	139	
		8"	F080M308DT908	40"	650	176	
		10"	F100M308DT908	40"	900	224	
		12"	F120M308DT908	40"	550	294	

Typical Installation

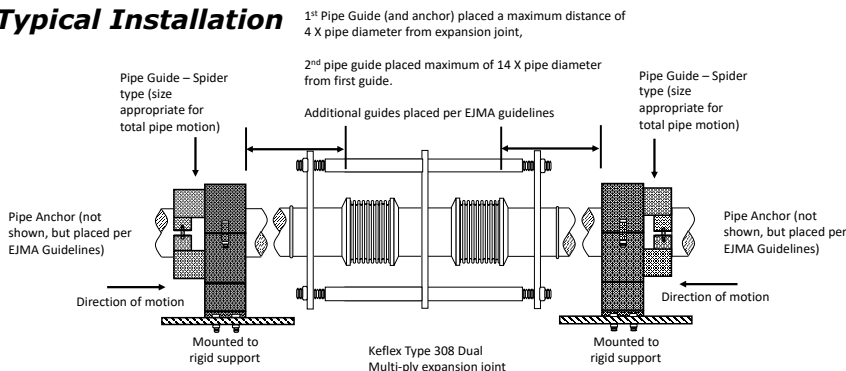

IMPORTANT LINKS

BROCHURE:	
INSTALLATION INSTRUCTIONS:	
TECHNICAL DATA:	
WEBSITE:	KELCOIND.COM



MADE IN THE USA

**1425 LAKE AVE
WOODSTOCK, IL 60098
815-334-3600**