



HVAC Products

SUBMITTAL

Mar 2018

311 SERIES EXPANSION JOINT 2" TRAVEL W/300# PLATE FLANGES

PROJECT:	
CUSTOMER:	
ENGINEER:	
ARCHITECT:	

MATERIALS OF CONSTRUCTION	
'A' PIPE SCH 40:	CARBON STEEL
'B' CAPSULE:	T-304 STN STL
'C' PLATE FLANGE:	CARBON STEEL

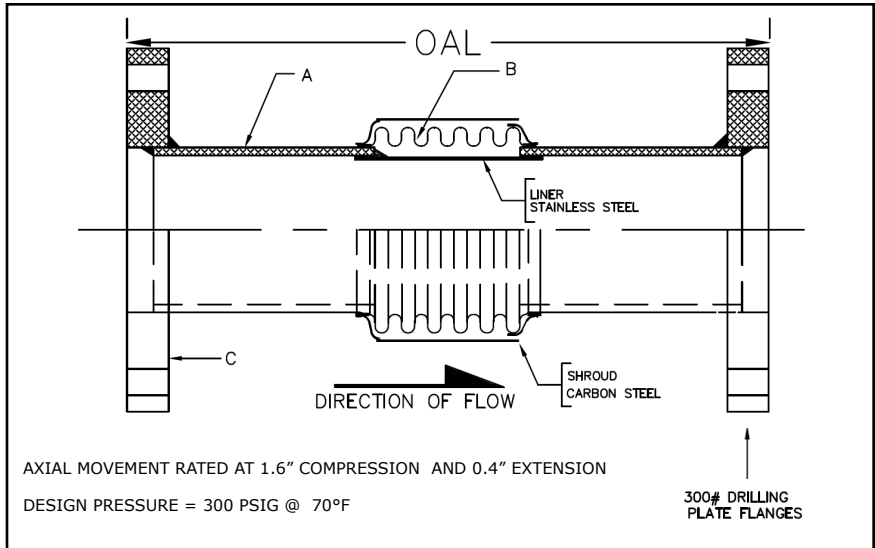

QTY	ID # OR TAG #	DIA (IN)	KEFLEX PART #	OAL	AXIAL FORCE TO COMPRESS (LBS)	WEIGHT (LBS)	3D Model (.stp)
		2"	F020H3113002	17"	175	17	
		2 1/2"	F024H3113002	17"	350	24	
		3"	F030H3113002	17"	225	30	
		4"	F040H3113002	17"	575	48	
		5"	F050H3113002	17"	350	63	
		6"	F060H3113002	17"	400	78	
		8"	F080H3113002	17"	575	114	
		10"	F100H3113002	17"	850	150	
		12"	F120H3113002	17"	475	205	

Typical Installation

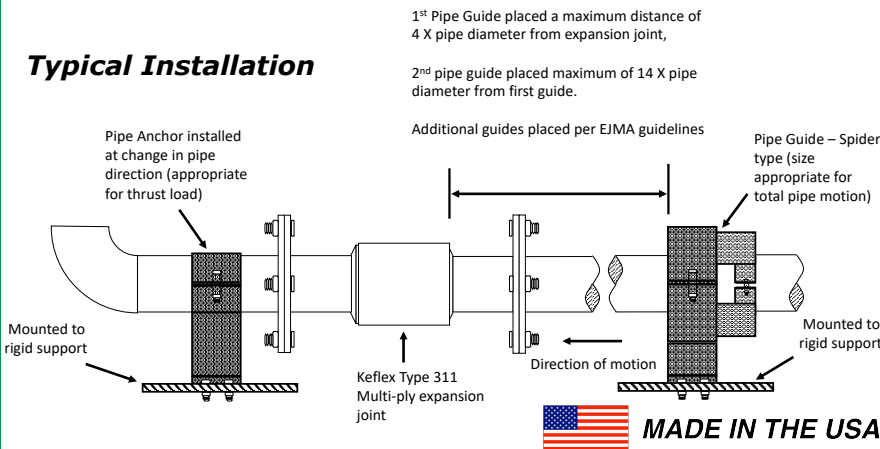

IMPORTANT LINKS	
BROCHURE:	
INSTALLATION INSTRUCTIONS:	
TECHNICAL DATA:	
WEBSITE:	KELCOIND.COM



MADE IN THE USA

**1425 LAKE AVE
WOODSTOCK, IL 60098
815-334-3600**