



HVAC Products

SUBMITTAL

Mar 2018

311 SERIES EXPANSION JOINT 3" TRAVEL W/300# PLATE FLANGES

PROJECT:	
CUSTOMER:	
ENGINEER:	
ARCHITECT:	

MATERIALS OF CONSTRUCTION	
'A' PIPE SCH 40:	CARBON STEEL
'B' CAPSULE:	T-304 STN STL
'C' PLATE FLANGE:	CARBON STEEL

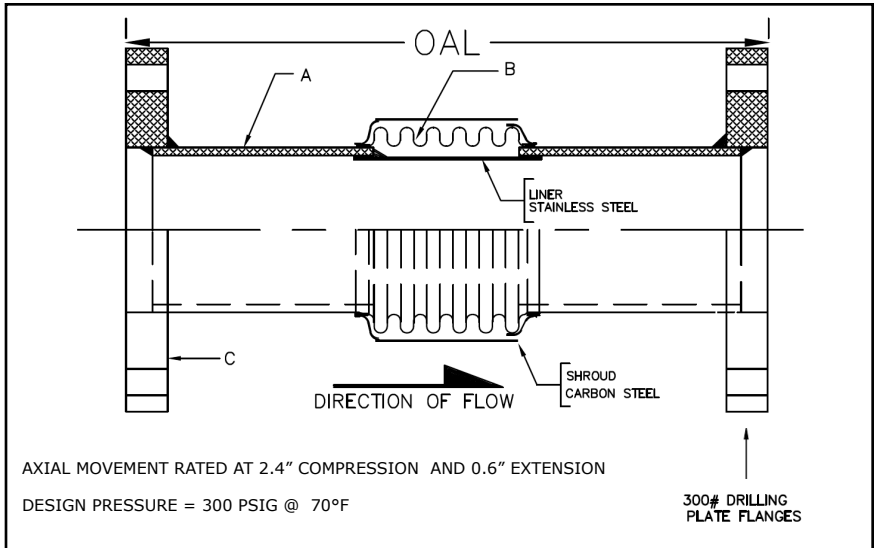

QTY	ID # OR TAG #	DIA (IN)	KEFLEX PART #	OAL	AXIAL FORCE TO COMPRESS (LBS)	WEIGHT (LBS)	3D Model (.stp)
		8"	F080H3113003	20"	750	124	
		10"	F100H3113003	20"	1000	165	
		12"	F120H3113003	20"	600	222	

Typical Installation

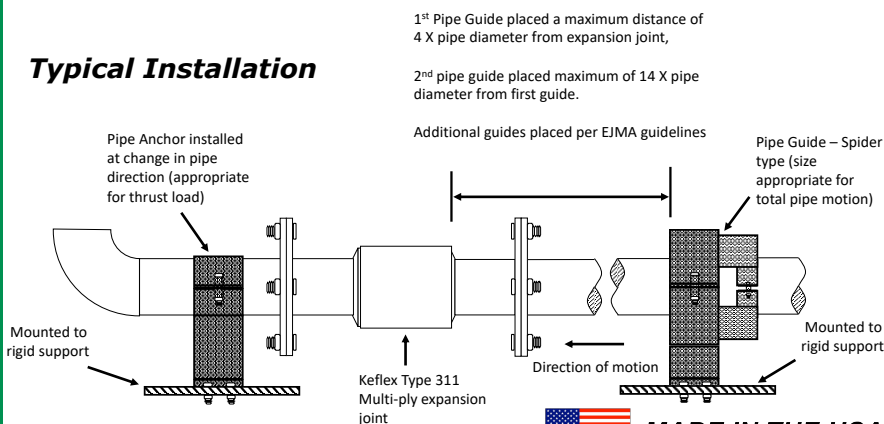

IMPORTANT LINKS	
BROCHURE:	
INSTALLATION INSTRUCTIONS:	
TECHNICAL DATA:	
WEBSITE:	KELCOIND.COM



MADE IN THE USA

1425 LAKE AVE
 WOODSTOCK, IL 60098
 815-334-3600