



HVAC Products

SUBMITTAL

Mar 2018

311 SERIES EXPANSION JOINT 1" TRAVEL W/300# PLATE FLANGES & TIE RODS

PROJECT:	
CUSTOMER:	
ENGINEER:	
ARCHITECT:	

MATERIALS OF CONSTRUCTION	
'A' PIPE SCH 40:	CARBON STEEL
'B' CAPSULE:	T-304 STN STL
'C' PLATE FLANGE:	CARBON STEEL
'D' TIE RODS/SPACERS	CARBON STEEL

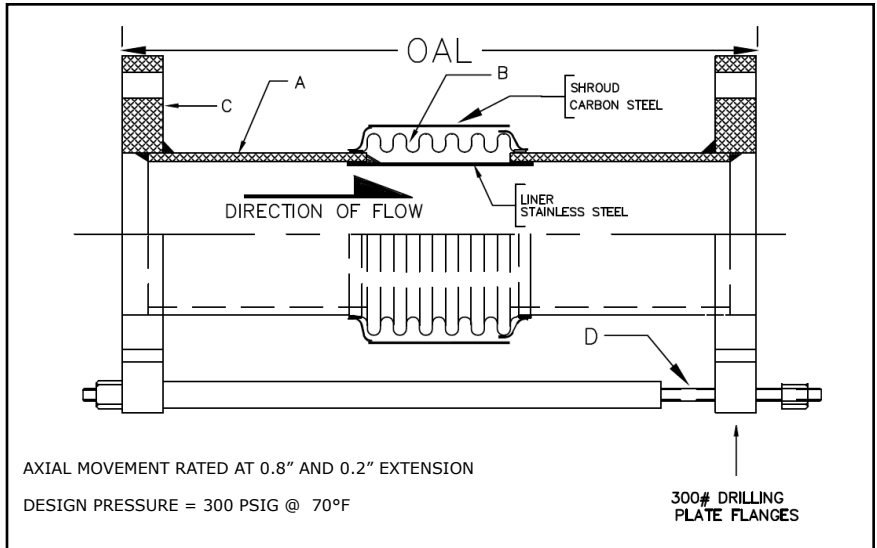

QTY	ID # OR TAG #	DIA (IN)	KEFLEX PART #	OAL	AXIAL FORCE TO COMPRESS (LBS)	WEIGHT (LBS)	3D Model (.stp)
		2"	F020H311T3001	15"	100	42	
		2 1/2"	F024H311T3001	15"	200	48	
		3"	F030H311T3001	15"	150	54	
		4"	F040H311T3001	15"	400	67	
		5"	F050H311T3001	15"	225	84	
		6"	F060H311T3001	15"	250	102	
		8"	F080H311T3001	15"	400	146	
		10"	F100H311T3001	15"	600	179	
		12"	F120H311T3001	15"	350	248	

Typical Installation

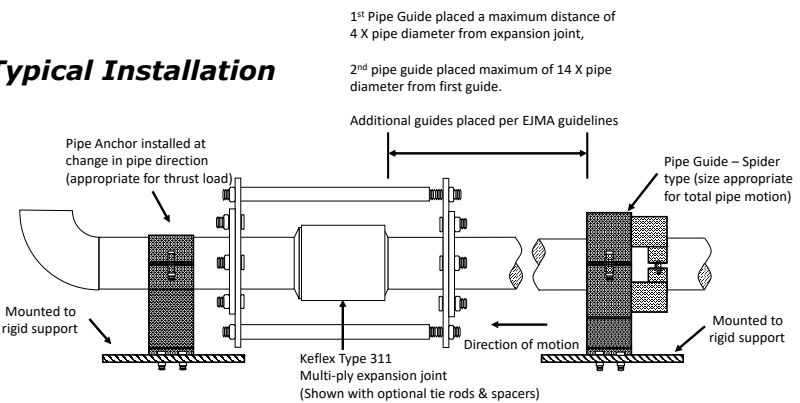

IMPORTANT LINKS	
BROCHURE:	
INSTALLATION INSTRUCTIONS:	
TECHNICAL DATA:	
WEBSITE:	KELCOIND.COM

MADE IN THE USA

**1425 LAKE AVE
WOODSTOCK, IL 60098
815-334-3600**