



HVAC Products

SUBMITTAL

Mar 2018

311 SERIES EXPANSION JOINT 1" TRAVEL W/150# PLATE FLANGES

PROJECT:	
CUSTOMER:	
ENGINEER:	
ARCHITECT:	

MATERIALS OF CONSTRUCTION	
'A' PIPE SCH 40:	CARBON STEEL
'B' CAPSULE:	T-304 STN STL
'C' PLATE FLANGE:	CARBON STEEL

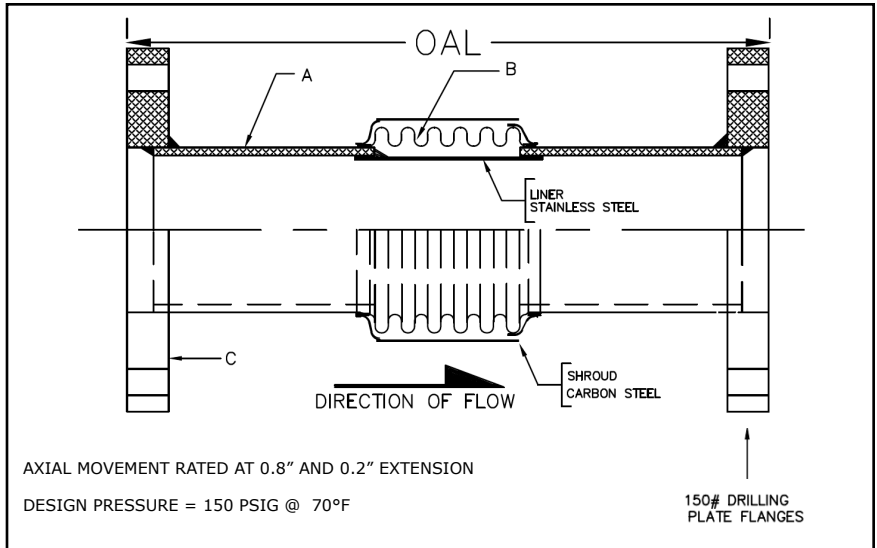

QTY	ID # OR TAG #	DIA (IN)	KEFLEX PART #	OAL	AXIAL FORCE TO COMPRESS (LBS)	WEIGHT (LBS)	3D Model (.stp)
		2"	F020M3111501	15"	100	13	
		2 1/2"	F024M3111501	15"	200	17	
		3"	F030M3111501	15"	150	21	
		4"	F040M3111501	15"	400	30	
		5"	F050M3111501	15"	225	44	
		6"	F060M3111501	15"	250	56	
		8"	F080M3111501	15"	400	91	
		10"	F100M3111501	15"	600	116	
		12"	F120M3111501	15"	350	164	

Typical Installation

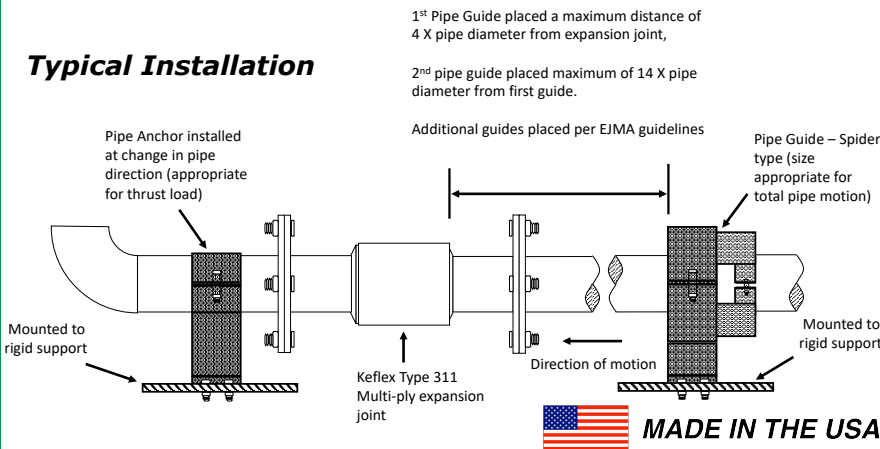

IMPORTANT LINKS

BROCHURE:	
INSTALLATION INSTRUCTIONS:	
TECHNICAL DATA:	
WEBSITE:	KELCOIND.COM

1425 LAKE AVE
WOODSTOCK, IL 60098
815-334-3600