

311 SERIES DUAL EXPANSION JOINT 8" TRAVEL W/150# PLATE FLANGES & TIE RODS

PROJECT:	
CUSTOMER:	
ENGINEER:	
ARCHITECT:	

MATERIALS OF CONSTRUCTION	
'A' PIPE SCH 40:	CARBON STEEL
'B' CAPSULE:	T-304 STN STL
'C' TIE RODS/SPACERS:	CARBON STEEL
'D' PLATE FLANGES:	CARBON STEEL

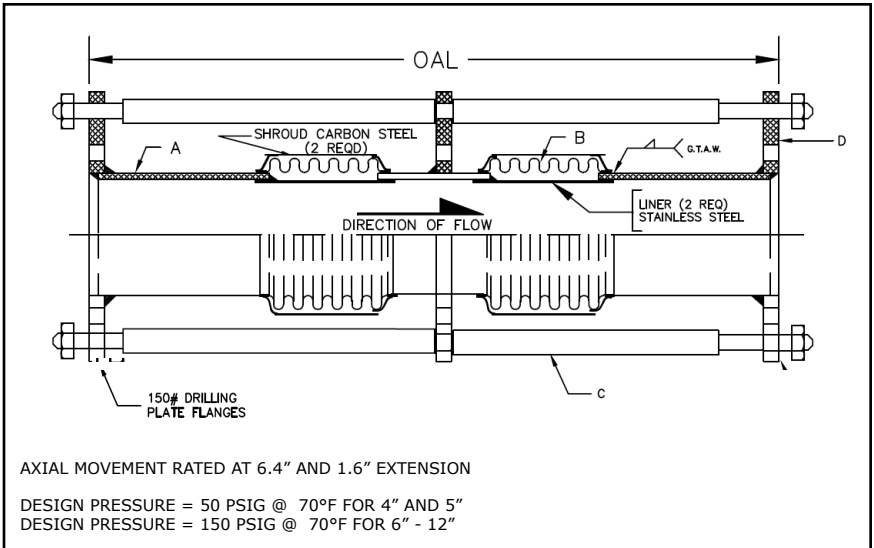

QTY	ID # OR TAG #	DIA (IN)	KEFLEX PART #	OAL	AXIAL FORCE TO COMPRESS (LBS)	WEIGHT (LBS)	3D Model (.stp)
		4"	F040L311DT1508	46"	625	119	
		5"	F050L311DT1508	46"	425	144	
		6"	F060M311DT1508	46"	500	165	
		8"	F080M311DT1508	46"	650	211	
		10"	F100M311DT1508	46"	900	261	
		12"	F120M311DT1508	46"	550	352	

Typical Installation

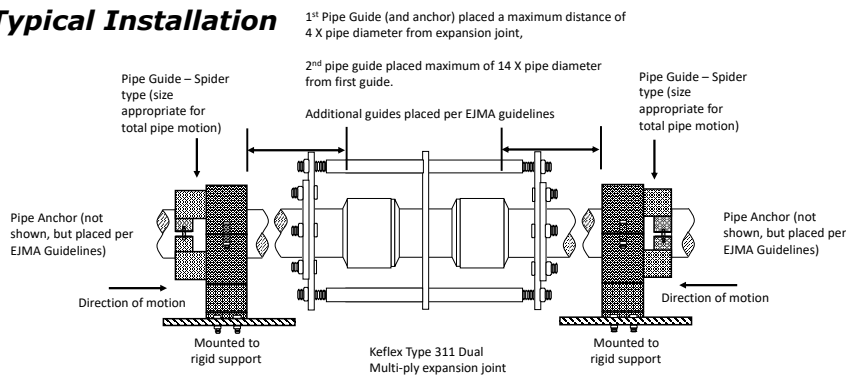

IMPORTANT LINKS	
BROCHURE:	
INSTALLATION INSTRUCTIONS:	
TECHNICAL DATA:	
WEBSITE:	KELCOIND.COM