



HVAC Products

# SUBMITTAL

Mar 2018

## 311 SERIES EXPANSION JOINT 2" TRAVEL W/150# PLATE FLANGES & TIE RODS

<b>PROJECT:</b>	
<b>CUSTOMER:</b>	
<b>ENGINEER:</b>	
<b>ARCHITECT:</b>	

MATERIALS OF CONSTRUCTION	
'A' PIPE SCH 40:	CARBON STEEL
'B' CAPSULE:	T-304 STN STL
'C' PLATE FLANGE:	CARBON STEEL
'D' TIE RODS/SPACERS	CARBON STEEL

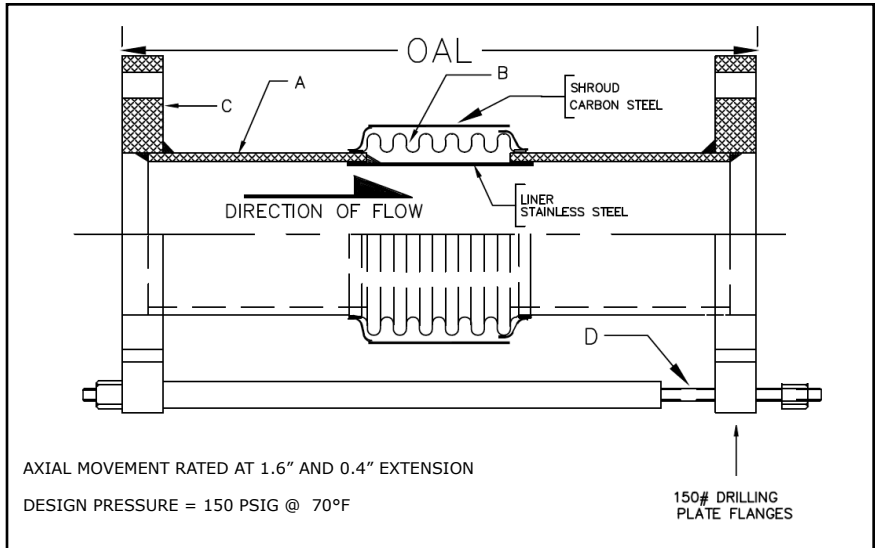

QTY	ID # OR TAG #	DIA (IN)	KEFLEX PART #	OAL	AXIAL FORCE TO COMPRESS (LBS)	WEIGHT (LBS)	3D Model (.stp)
		2"	F020M311T1502	17"	175	29	
		2 1/2"	F024M311T1502	17"	350	35	
		3"	F030M311T1502	17"	225	40	
		4"	F040M311T1502	17"	575	51	
		5"	F050M311T1502	17"	350	65	
		6"	F060M311T1502	17"	400	80	
		8"	F080M311T1502	17"	575	117	
		10"	F100M311T1502	17"	850	154	
		12"	F120M311T1502	17"	475	209	

### Typical Installation

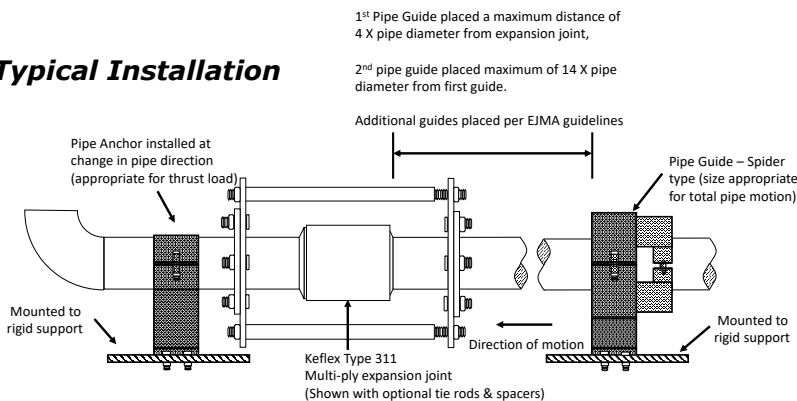

IMPORTANT LINKS	
BROCHURE:	
INSTALLATION INSTRUCTIONS:	
TECHNICAL DATA:	
WEBSITE:	<a href="http://KELCOIND.COM">KELCOIND.COM</a>



MADE IN THE USA

**1425 LAKE AVE  
WOODSTOCK, IL 60098  
815-334-3600**