



HVAC Products

SUBMITTAL

Mar 2018

311 SERIES EXPANSION JOINT 1" TRAVEL W/GROOVE ENDS

PROJECT:	
CUSTOMER:	
ENGINEER:	
ARCHITECT:	

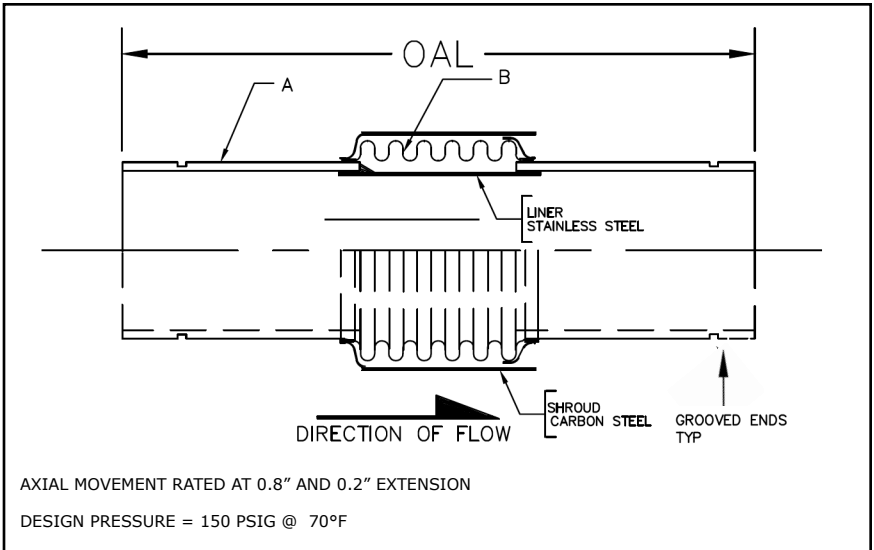

MATERIALS OF CONSTRUCTION	
'A' PIPE SCH 40:	CARBON STEEL
'B' CAPSULE:	T-304 STN STL

QTY	ID # OR TAG #	DIA (IN)	KEFLEX PART #	OAL	AXIAL FORCE TO COMPRESS (LBS)	WEIGHT (LBS)	3D Model (.stp)
		2"	F020M311VG01	15"	100	5	
		2 1/2"	F024M311VG01	15"	200	7	
		3"	F030M311VG01	15"	150	10	
		4"	F040M311VG01	15"	400	16	
		5"	F050M311VG01	15"	225	24	
		6"	F060M311VG01	15"	250	33	
		8"	F080M311VG01	15"	400	49	
		10"	F100M311VG01	15"	600	66	
		12"	F120M311VG01	15"	350	85	

Typical Installation

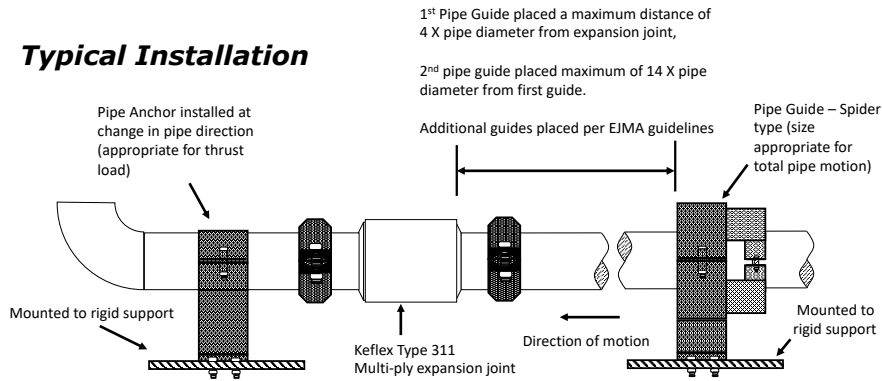

IMPORTANT LINKS	
BROCHURE:	
INSTALLATION INSTRUCTIONS:	
TECHNICAL DATA:	
WEBSITE:	KELCOIND.COM

MADE IN THE USA

**1425 LAKE AVE
WOODSTOCK, IL 60098
815-334-3600**