



HVAC Products

SUBMITTAL

Mar 2018

311 SERIES EXPANSION JOINT 4" TRAVEL W/GROOVE ENDS

PROJECT:	
CUSTOMER:	
ENGINEER:	
ARCHITECT:	

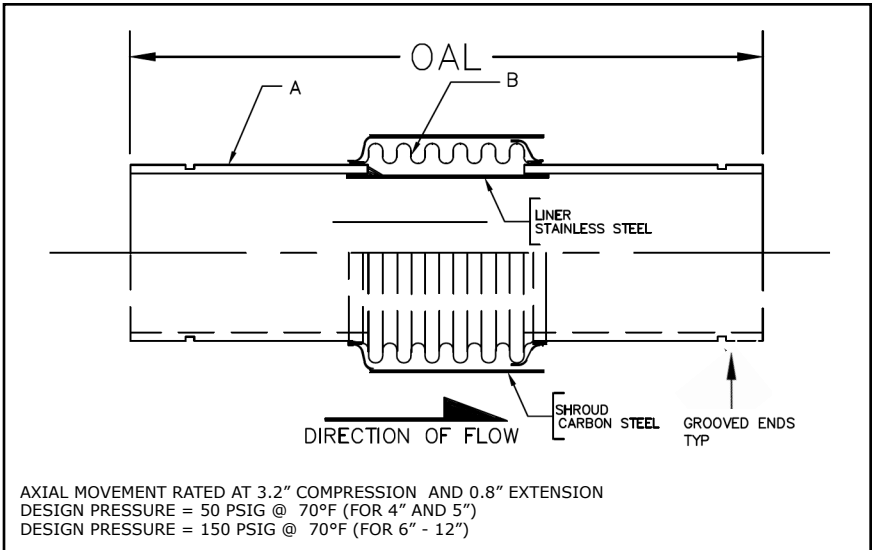

MATERIALS OF CONSTRUCTION	
'A' PIPE SCH 40:	CARBON STEEL
'B' CAPSULE:	T-304 STN STL

QTY	ID # OR TAG #	DIA (IN)	KEFLEX PART #	OAL	AXIAL FORCE TO COMPRESS (LBS)	WEIGHT (LBS)	3D Model (.stp)
		4"	F040L311VG04	24"	625	21	
		5"	F050L311VG04	24"	425	32	
		6"	F060M311VG04	24"	500	48	
		8"	F080M311VG04	24"	650	66	
		10"	F100M311VG04	24"	900	90	
		12"	F120M311VG04	24"	550	116	

Typical Installation

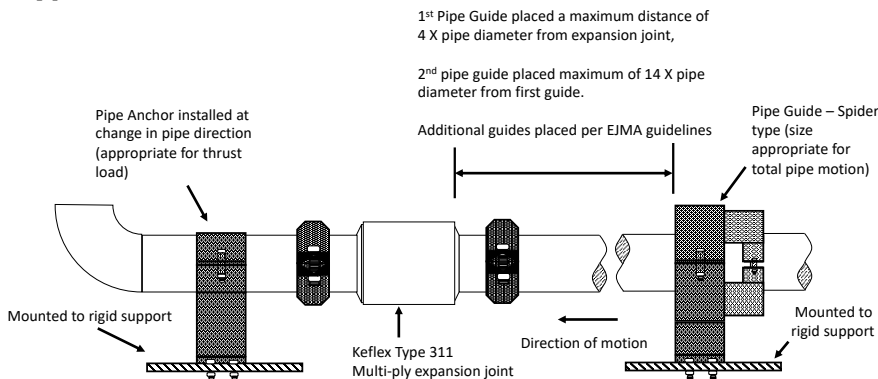

IMPORTANT LINKS	
BROCHURE:	
INSTALLATION INSTRUCTIONS:	
TECHNICAL DATA:	
WEBSITE:	KELCOIND.COM



MADE IN THE USA

1425 LAKE AVE
 WOODSTOCK, IL 60098
 815-334-3600