



HVAC Products

SUBMITTAL

Mar 2018

311 SERIES DUAL EXPANSION JOINT 6" TRAVEL W/WELD ENDS & TIE RODS

PROJECT:	
CUSTOMER:	
ENGINEER:	
ARCHITECT:	

MATERIALS OF CONSTRUCTION	
'A' PIPE SCH 40:	CARBON STEEL
'B' CAPSULE:	T-304 STN STL
'C' TIE RODS/SPACERS:	CARBON STEEL
'D' PLATE FLANGES:	CARBON STEEL

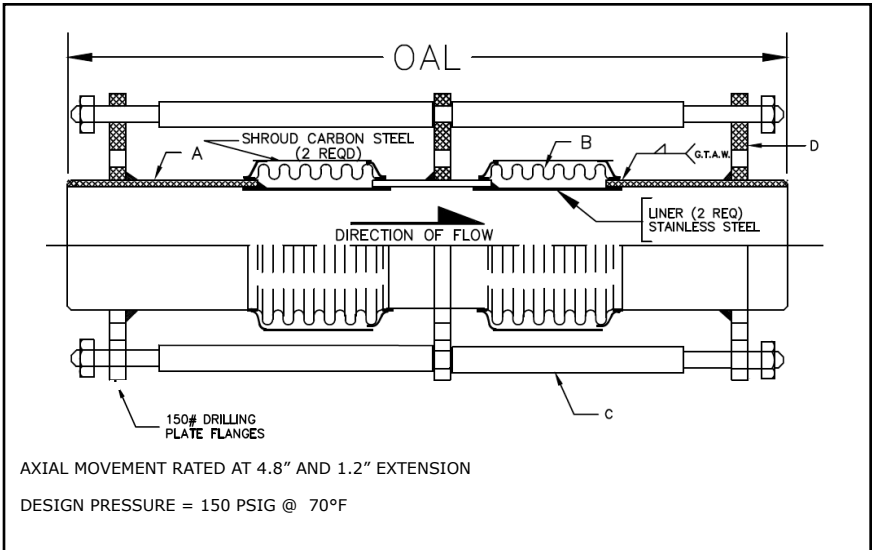

QTY	ID # OR TAG #	DIA (IN)	KEFLEX PART #	OAL	AXIAL FORCE TO COMPRESS (LBS)	WEIGHT (LBS)	3D Model (.stp)
		2"	F020M311DT906	36"	175	57	
		2 1/2"	F024M311DT906	36"	350	58	
		3"	F030M311DT906	36"	225	87	
		4"	F040M311DT906	36"	575	109	
		5"	F050M311DT906	36"	350	132	
		6"	F060M311DT906	36"	400	151	
		8"	F080M311DT906	36"	575	198	
		10"	F100M311DT906	36"	850	246	
		12"	F120M311DT906	36"	475	332	

Typical Installation

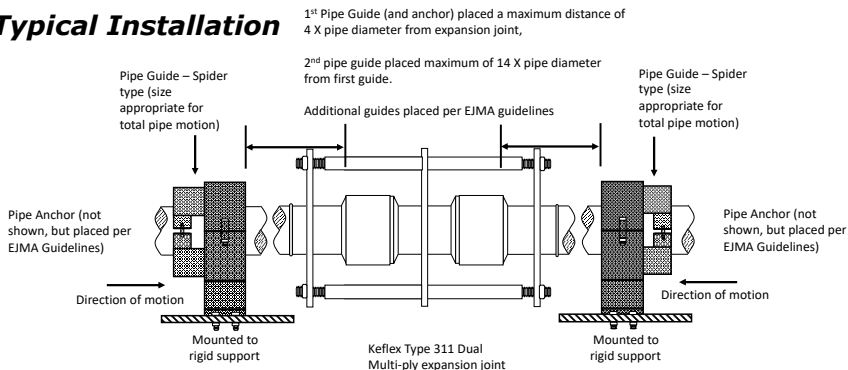

IMPORTANT LINKS

BROCHURE:	
INSTALLATION INSTRUCTIONS:	
TECHNICAL DATA:	
WEBSITE:	KELCOIND.COM



MADE IN THE USA

**1425 LAKE AVE
WOODSTOCK, IL 60098
815-334-3600**