



HVAC Products

SUBMITTAL

Mar 2018

311 SERIES EXPANSION JOINT 4" TRAVEL W/WELD ENDS & TIE RODS

| | |
|-------------------|--|
| PROJECT: | |
| CUSTOMER: | |
| ENGINEER: | |
| ARCHITECT: | |

| MATERIALS OF CONSTRUCTION | |
|---------------------------|---------------|
| 'A' PIPE SCH 40: | CARBON STEEL |
| 'B' CAPSULE: | T-304 STN STL |
| 'C' PLATE FLANGE: | CARBON STEEL |
| 'D' TIE RODS/SPACERS | CARBON STEEL |

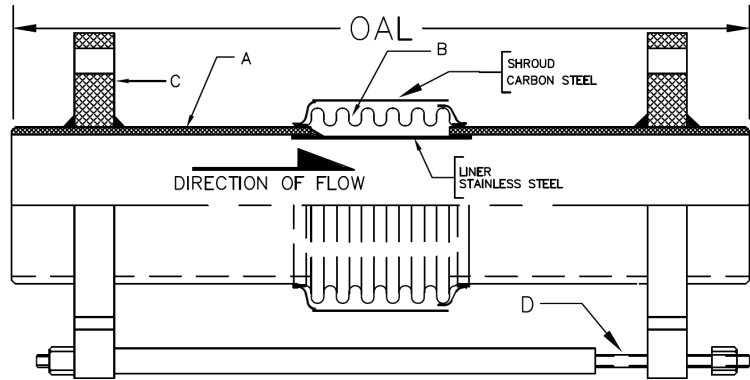

AXIAL MOVEMENT RATED AT 3.2" AND 0.8" EXTENSION

DESIGN PRESSURE = 50 PSIG @ 70°F FOR 4" AND 5"
DESIGN PRESSURE = 150 PSIG @ 70°F FOR 6" - 12"

| QTY | ID # OR TAG # | DIA (IN) | KEFLEX PART # | OAL | AXIAL FORCE TO COMPRESS (LBS) | WEIGHT (LBS) | 3D Model (.stp) |
|-----|---------------|----------|---------------|-----|-------------------------------|--------------|-----------------|
| | | 4" | F040L311T904 | 24" | 625 | 56 | |
| | | 5" | F050L311T904 | 24" | 425 | 74 | |
| | | 6" | F060M311T904 | 24" | 500 | 90 | |
| | | 8" | F080M311T904 | 24" | 650 | 131 | |
| | | 10" | F100M311T904 | 24" | 900 | 173 | |
| | | 12" | F120M311T904 | 24" | 550 | 234 | |

Typical Installation

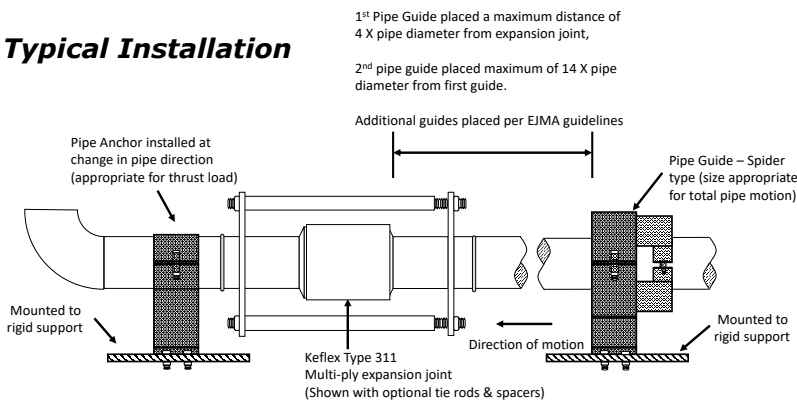

IMPORTANT LINKS

| | |
|----------------------------|--|
| BROCHURE: | |
| INSTALLATION INSTRUCTIONS: | |
| TECHNICAL DATA: | |
| WEBSITE: | KELCOIND.COM |



MADE IN THE USA

1425 LAKE AVE
WOODSTOCK, IL 60098
815-334-3600