



HVAC Products

SUBMITTAL

Mar 2018

151 SERIES PUMP CONNECTOR W/WELDED 150# PLATE FLANGES & TIE RODS

PROJECT:	
CUSTOMER:	
ENGINEER:	
ARCHITECT:	

MATERIALS OF CONSTRUCTION	
BELLOWS:	T-304 STN STL
FLANGES:	CARBON STEEL
BOLT/NUT & SLEEVE:	CARBON STEEL

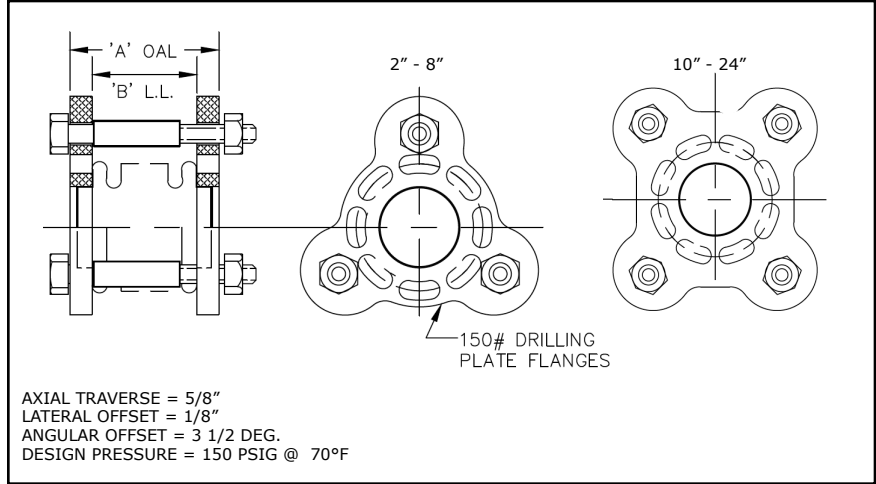

QTY	ID # OR TAG #	DIA (IN)	KEFLEX PART #	'B' LL	'A' OAL	3D Model (.stp)
		2"	F020151TR1215	3 1/2"	5"	
		2 1/2"	F024151TR1215	3 1/2"	5"	
		3"	F030151TR1215	3 1/2"	5"	
		4"	F040151TR1215	3 1/2"	5"	
		5"	F050151TR1215	3 1/2"	5"	
		6"	F060151TR1215	3 1/2"	5"	
		8"	F080151TR1215	3 1/2"	5"	
		10"	F100151TR1215	3 1/2"	5"	
		12"	F120151TR1215	3 1/2"	5"	
		14"	F140151TR1215	5"	9"	
		16"	F160151TR1215	5"	9"	
		18"	F180151TR1215	5"	9"	
		20"	F200151TR1215	5"	9"	
		24"	F240151TR1215	5"	9"	

IMPORTANT LINKS

BROCHURE:		TECHNICAL DATA:	
INSTALLATION INSTRUCTIONS:		WEBSITE:	FLEX-WELD.COM



MADE IN THE USA

1425 LAKE AVE
 WOODSTOCK, IL 60098
 00-323-6893