



HVAC Products

SUBMITTAL

Mar 2018

EXTERNALLY PRESSURIZED EXPANSION JOINT 300# 6" COMPRESSION W/GROOVE ENDS

PROJECT:	
CUSTOMER:	
ENGINEER:	
ARCHITECT:	

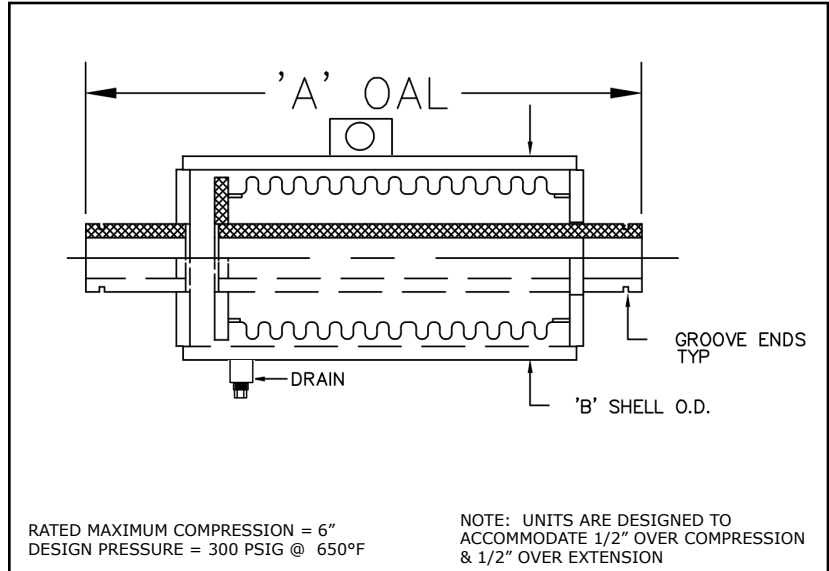

MATERIALS OF CONSTRUCTION	
BELLOW:	T-321 STAINLESS STEEL
PIPE:	CARBON STEEL SCH. STD.
PLATES:	CARBON STEEL

QTY	ID # OR TAG #	DIAMETER (IN)	KEFLEX PART #	PRESSURE THRUST @ DESIGN PRES.	'A' OAL	'B' SHELL O.D.	SPRING RATE (LB/IN)	3D Model (.stp)
		1"	F010SEP21HVGM	2400 LBF	30 1/4"	4 1/2"	40	
		1 1/4"	F012SEP21HVGM	2400 LBF	30 1/2"	4 1/2"	40	
		1 1/2"	F014SEP21HVGM	2400 LBF	30 1/2"	4 1/2"	40	
		2"	F020SEP21HVGM	2400 LBF	31"	4 1/2"	40	
		2 1/2"	F024SEP21HVGM	6100 LBF	33 7/8"	6 5/8"	150	
		3"	F030SEP21HVGM	6100 LBF	33 7/8"	6 5/8"	150	
		3 1/2"	F034SEP21HVGM	6100 LBF	33 7/8"	6 5/8"	150	
		4"	F040SEP21HVGM	9000 LBF	34 1/8"	8 5/8"	150	
		5"	F050SEP21HVGM	20500 LBF	35 3/8"	10 3/4"	350	
		6"	F060SEP21HVGM	20500 LBF	35 3/8"	10 3/4"	350	
		8"	F080SEP21HVGM	24500 LBF	32 1/4"	12 3/4"	450	
		10"	F100SEP21HVGM	36700 LBF	32 1/4"	16"	650	
		12"	F120SEP21HVGM	50500 LBF	32 1/4"	18"	950	

IMPORTANT LINKS	
BROCHURE:	
INSTALLATION INSTRUCTIONS:	
WEBSITE:	FLEX-WELD.COM



MADE IN THE USA

**1425 LAKE AVE
 WOODSTOCK, IL 60098
 800-323-6893**