



HVAC Products

# SUBMITTAL

Mar 2018

DUAL EXTERNALLY PRESSURIZED EXPANSION JOINT 300# 16" COMPRESSION W/GROOVE ENDS

PROJECT:	
CUSTOMER:	
ENGINEER:	
ARCHITECT:	

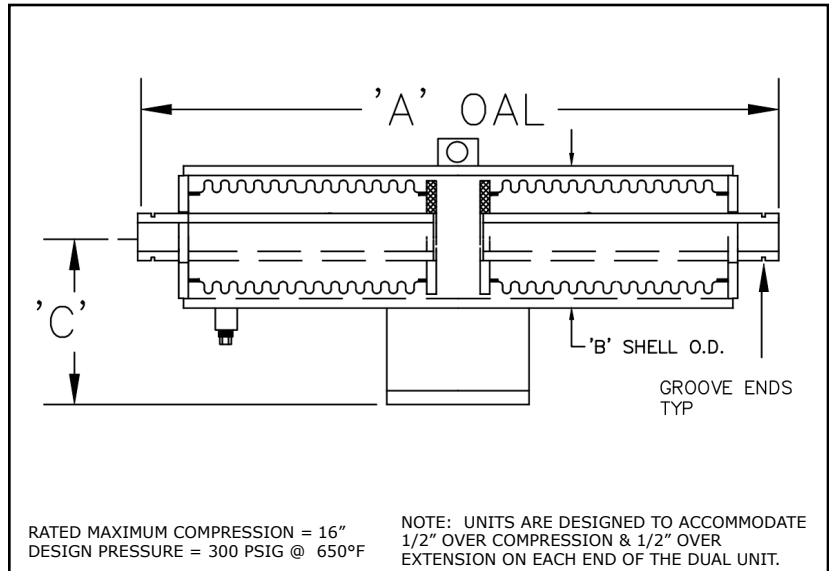

MATERIALS OF CONSTRUCTION	
BELLOW:	T-321 STAINLESS STEEL
PIPE:	CARBON STEEL SCH. STD.
PLATES:	CARBON STEEL

QTY	ID # OR TAG #	DIAMETER (IN)	KEFLEX PART #	PRESSURE THRUST @ DESIGN PRES.	'A' OAL	'B' SHELL O.D.	'C' C/L	SPRING RATE (LB/IN)	3D Model (.stp)
		1"	F010DEP21HVGL	2400 LBF	65"	4 1/2"	4"	30	
		1 1/4"	F012DEP21HVGL	2400 LBF	65 1/4"	4 1/2"	4"	30	
		1 1/2"	F014DEP21HVGL	2400 LBF	65 1/4"	4 1/2"	4"	30	
		2"	F020DEP21HVGL	2400 LBF	66 1/2"	4 1/2"	4 1/2"	30	
		2 1/2"	F024DEP21HVGL	6100 LBF	78 1/2"	6 5/8"	4 1/2"	120	
		3"	F030DEP21HVGL	6100 LBF	78 1/2"	6 5/8"	5"	120	
		3 1/2"	F034DEP21HVGL	6100 LBF	78 1/2"	6 5/8"	6 1/4"	120	
		4"	F040DEP21HVGL	9000 LBF	71"	8 5/8"	6 1/4"	120	
		5"	F050DEP21HVGL	20500 LBF	80 1/2"	10 3/4"	7 1/2"	250	
		6"	F060DEP21HVGL	20500 LBF	80 1/2"	10 3/4"	7 1/2"	250	
		8"	F080DEP21HVGL	24500 LBF	73 1/2"	12 3/4"	8 1/2"	300	
		10"	F100DEP21HVGL	36700 LBF	73 1/2"	16"	10 1/4"	500	
		12"	F120DEP21HVGL	50500 LBF	73 1/2"	18"	11 1/4"	700	

IMPORTANT LINKS	
BROCHURE:	
INSTALLATION INSTRUCTIONS:	
WEBSITE:	<a href="http://KELCOIND.COM">KELCOIND.COM</a>



MADE IN THE USA

1425 LAKE AVE  
WOODSTOCK, IL 60098  
815-334-3600