



HVAC Products

SUBMITTAL

Mar 2018

EXTERNALLY PRESSURIZED EXPANSION JOINT 150# 6" COMPRESSION W/GROOVE ENDS

PROJECT:	
CUSTOMER:	
ENGINEER:	
ARCHITECT:	

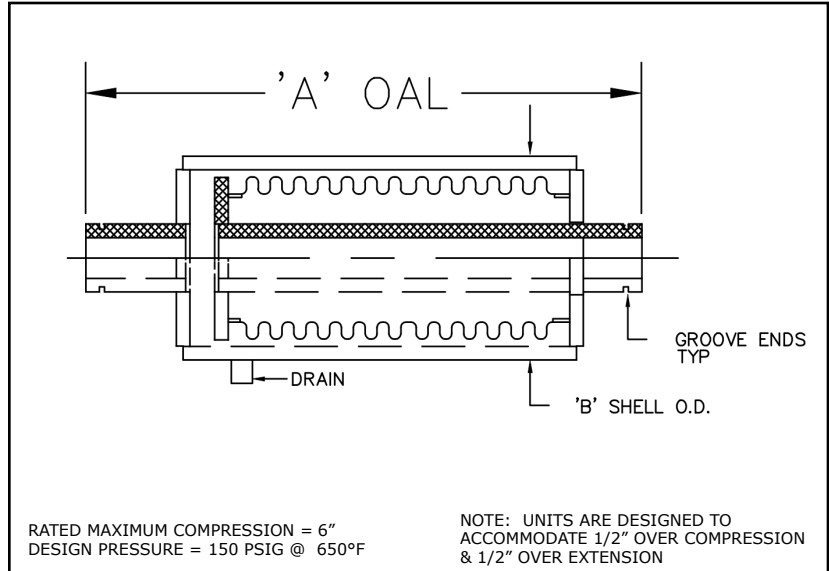

MATERIALS OF CONSTRUCTION	
BELLOW:	300 SERIES STAINLESS STEEL
PIPE:	CARBON STEEL SCH. STD.
PLATES:	CARBON STEEL

QTY	ID # OR TAG #	DIAMETER (IN)	KEFLEX PART #	PRESSURE THRUST @ DESIGN PRES.	'A' OAL	'B' SHELL O.D.	SPRING RATE (LB/IN)	3D Model (.stp)
		1"	F010SEP04MVGM	1200 LBF	29 1/4"	4 1/2"	25	
		1 1/4"	F012SEP04MVGM	1200 LBF	29 1/2"	4 1/2"	25	
		1 1/2"	F014SEP04MVGM	1200 LBF	29 1/2"	4 1/2"	25	
		2"	F020SEP04MVGM	1200 LBF	30"	4 1/2"	25	
		2 1/2"	F024SEP21MVGM	3000 LBF	32 7/8"	6 5/8"	100	
		3"	F030SEP21MVGM	3000 LBF	32 7/8"	6 5/8"	100	
		3 1/2"	F034SEP21MVGM	3000 LBF	32 7/8"	6 5/8"	100	
		4"	F040SEP21MVGM	4500 LBF	33 1/8"	8 5/8"	105	
		5"	F050SEP21MVGM	10100 LBF	34 3/8"	10 3/4"	225	
		6"	F060SEP21MVGM	10100 LBF	34 3/8"	10 3/4"	225	
		8"	F080SEP21MVGM	12250 LBF	31 1/4"	12 3/4"	320	
		10"	F100SEP21MVGM	18300 LBF	31 1/4"	16"	350	
		12"	F120SEP21MVGM	25200 LBF	31 1/4"	18"	650	

IMPORTANT LINKS	
BROCHURE:	
INSTALLATION INSTRUCTIONS:	
WEBSITE:	KELCOIND.COM



MADE IN THE USA

**1425 LAKE AVE
WOODSTOCK, IL 60098
Ph: 815-334-3600**