



HVAC Products

SUBMITTAL

Mar 2018

EXTERNALLY PRESSURIZED EXPANSION JOINT 300# 4" COMPRESSION W/GROOVE ENDS

PROJECT:	
CUSTOMER:	
ENGINEER:	
ARCHITECT:	

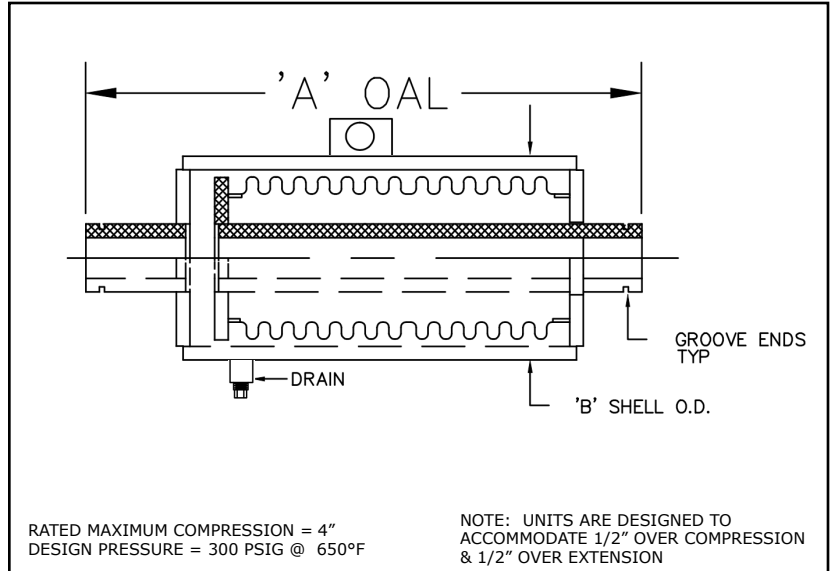

MATERIALS OF CONSTRUCTION	
BELLOW:	T-321 STAINLESS STEEL
PIPE:	CARBON STEEL SCH. STD.
PLATES:	CARBON STEEL

QTY	ID # OR TAG #	DIAMETER (IN)	KEFLEX PART #	PRESSURE THRUST @ DESIGN PRES.	'A' OAL	'B' SHELL O.D.	SPRING RATE (LB/IN)	3D Model (.stp)
		1"	F010SEP21HVGS	2400 LBF	23"	4 1/2"	60	
		1 1/4"	F012SEP21HVGS	2400 LBF	23 1/2"	4 1/2"	60	
		1 1/2"	F014SEP21HVGS	2400 LBF	23 1/2"	4 1/2"	60	
		2"	F020SEP21HVGS	2400 LBF	24"	4 1/2"	60	
		2 1/2"	F024SEP21HVGS	6100 LBF	26 7/8"	6 5/8"	230	
		3"	F030SEP21HVGS	6100 LBF	26 7/8"	6 5/8"	230	
		3 1/2"	F034SEP21HVGS	6100 LBF	26 7/8"	6 5/8"	230	
		4"	F040SEP21HVGS	9000 LBF	26 1/4"	8 5/8"	230	
		5"	F050SEP21HVGS	20500 LBF	27 3/8"	10 3/4"	500	
		6"	F060SEP21HVGS	20500 LBF	27 3/8"	10 3/4"	500	
		8"	F080SEP21HVGS	24500 LBF	25 3/4"	12 3/4"	600	
		10"	F100SEP21HVGS	36700 LBF	25 3/4"	16"	850	
		12"	F120SEP21HVGS	50500 LBF	25 3/4"	18"	1250	

IMPORTANT LINKS	
BROCHURE:	
INSTALLATION INSTRUCTIONS:	
WEBSITE:	KELCOIND.COM



MADE IN THE USA

**1425 LAKE AVE
WOODSTOCK, IL 60098
Ph: 815-334-3600**